

Table of Contents

Thank you for purchasing the Primal RC 1/5 Scale Monster Truck.

	Pg.
Safety Guidelines	01
Terms of Use	01
Safety is Your Responsibility	02
Gas Engine Use Warning	02
Assembly Instructions	03
Wiring Diagram	04
Remote Engine Killswitch & Fail-Safe	04
Radio Details	05
Before You Drive	06
Running Your Truck	07
After you Drive	07
Choke Removal Instructions	08
Steering Servo Saver Adjustments	08
Brake Adjustments	09
Transmission Gears Adjustment	10
Troubleshooting Guide	11-12
Assembly	
Differential	13
Front Axle	14-18
Rear Axle	19-21
Transmission	21-25
Engine	25-27
Chassis	28-32
Fuel Tank	33
Receiver Box	34-35
Main Sway Bar	36
Linkage	37
Axle	38
Shock	39-40
Damper Shock	41
Sway Bar Link	42
Tire	44-45
Roll Cage	45-49
Body	49-51
Parts List	52

This manual contains the instructions you need to operate and maintain your truck. It is very important that you take the time to read and understand the instructions and radio manual. Make sure you read and follow the precautions and warnings in the Safety Guidelines section. These guidelines will educate you on how to run your truck safely and maximize its longevity and performance.

This truck requires advanced R/C user experience and expertise. You must be 18 years of age or older to operate this vehicle. Even if you are an experienced R/C driver, it is important to read and follow the safety guidelines in this manual.

If you have any questions regarding this vehicle or this manual: Stop. Do not use this vehicle and contact us at sales@primalrc.com.

Thank you again for your purchase and we look forward to exceeding your expectations.

Safety Guidelines

WARNING – RISK OF FIRE, INJURY OR DEATH

The truck is not a toy. The truck requires an advanced set of skills and is not intended for use by children or minors under the age of 18. The truck is intended to be purchased and operated by competent, adult R/C users possessing qualified skills and experienced driving ability. The user of this vehicle should be practical, mature, intelligent and display good common sense.

Caution must be taken to ensure the safety of yourself and others around you. This truck is very large and is capable of high speed and quick acceleration. Collisions of a critical nature (injury, death, severe property damage) can result if the truck is operated in a careless or unsafe manner. Always take great care to make sure all systems are working properly before operating. The user must be aware of their limits and abilities. Make certain to have adequate space where the truck can be run safely.

The truck requires the use of 2-stroke gasoline for its engine. Gas engines and 2-stroke gasoline have a very high risk of fire and injury if they are handled improperly. The truck comes equipped with a NI-MH receiver battery. Please read and understand the proper procedures for charging the battery.

The user must read and understand all the included instructions regarding the proper operation, maintenance and safety precautions in using a 2-cycle gas engine and charging batteries.

Instruction Videos Available at

PrimalRC.com/Video/TruckInstructions

Terms of Use

This product is sold by Primal RC with the understanding that the buyer accepts full responsibility for all actions associated with its use. Serious injury, property damage, or death can result from driving the monster truck or using any of the included accessories in an unsafe or irresponsible way. The buyer assumes all liability with this product including any actions that occur due to a failure to follow its safety and operating instructions resulting in unsafe or improper use or any action that violates the pertinent laws and regulations. Primal RC, and all the Primal RC dealers, will not be held accountable under any circumstances with the use of this product resulting in property damage, personal injury, or death. This includes any willful or unintentional damages that may arise out of the assembly or use of the product or its accessories. The user accepts all liability by the act of using and operating the truck and releases Primal RC, and all Primal RC dealers of any and all liability associated with its use. Primal RC requests that you do not use this product if you as a user do not accept liability of ownership. If you don't accept liability, please do not open any of the enclosed accessories, do not attempt to start it, and contact us to make arrangements to return the product. Used vehicles cannot be accepted for returns or exchanges under any circumstances. The material included in this manual can be changed without notice. Primal RC reserves the right to make improvements to the products with no commitment to integrate those improvements into products sold previously. The manual is subject to change at the discretion of Primal RC. For the latest version of the manual please visit www.PrimalRC.com.

If you have any questions regarding this Terms of Use, stop and do not go any further. Do not run your vehicle and contact Primal RC at sales@primalrc.com.

Safety is Your Responsibility

- Your radio system may be subject to radio interference from many sources that are out of your control. Please be aware that radio interference may cause a temporary loss of control. Allow adequate space in all directions when running your truck to prevent collisions if radio interference should occur.
- Test the range of your transmitter in the area you are driving. Make sure not to drive too far and go out of range.
- After testing the range, start by driving slowly in the area to make sure there is no interference that can cause temporary losses of control.
- Always test the failsafe system every time before use to ensure it's working properly (instructions are in the radio manual).
- Use new or freshly charged batteries in order to boost signal output power and range.
- The motor and exhaust become hot during use. Be careful not to touch them while hot to avoid getting burned.
- Drive in the proper area. This product is not designed to be used in heavy traffic areas where its operation would cause pedestrian and vehicle interruptions. This is recommended to prevent collisions causing property damage, injury, or death.
- Try to always bring a friend while driving. Another set of eyes is helpful to identify potential hazards such as an animal or person crossing in the driving path.
- Always have a clear view of the model when driving. Do not drive at night or when your vision may be blocked in any way.
- Don't drive the model too close to you, other persons, or property where collisions may occur. Allow a comfortable amount of space to maneuver the truck.
- Be sure to check over the truck after each driving session. Check for damage or any loose parts and correct any issues right away before using again. Make sure to check and tighten the wheel nuts before each session.
- Do not pick up the truck by its wheels or tires. Keep your hands free and clear of any moving parts when the electronics are turned on. Gravel, dirt, sticks, and other debris can be kicked up from the rear wheels during aggressive starts. Avoid standing directly behind the truck and make sure other watchers are at a safe distance to avoid being hit. Eye protection is always recommended.
- Avoid making changes not shown or suggested in the instruction manual. You can cause damage to the model and injury to yourself or others if the product is altered in a way not intended.
- Remember: SAFETY FIRST. Create a safe environment to run the truck and use good common sense. This will ensure maximal enjoyment while using the truck.

Gas Engine Use Warning

- A mixture of gasoline and 2-stroke oil is used for fuel. Please use caution when handling fuel.
- Keep fuel away from open flames, heating sources, direct sunlight, smoke, batteries or any ignition source. Store fuel in a well-ventilated area.
- Store fuel and truck in a location children can't access.
- Keep fuel and truck away from children.
- Gasoline is flammable, toxic, and can produce noxious vapors. The exhaust emitted from the truck can also produce noxious vapors. These vapors can irritate eyes, respiration, and be dangerous to your health. Always operate the truck in a well-ventilated area.
- The 2-cycle engine that comes on this truck only uses a mix of gasoline and 2-stroke oil. The oil/gas mix is how the engine is lubricated. Never run straight gas through the engine as catastrophic damage may result. Never use glow fuels intended for R/C car use.



WARNING – FIRE RISK: EMPTY THE FUEL TANK BEFORE STORING THE TRUCK.

Assembly Instructions

This truck is shipped in two boxes. One box contains the main chassis with body installed, sticker sheets, two wheels, transmitter, battery, charger and accessories. The second box contains front and rear axle, brake system, two wheels and four shocks.

Before assembling and starting your truck, read and understand all manuals and familiarize yourself with the truck completely. If you decide this truck is not the right choice for you or you do not want to assume responsibility for your safety, then do not attempt to assemble or start it. Do not run the vehicle at all and please contact us to make arrangements to return the vehicle.

If your vehicle arrives with damage from transit please do not run the vehicle, and contact us instead. Used vehicles cannot be accepted for returns or exchanges under any circumstances. If you have any questions about your truck, please email us at sales@primalrc.com. Maintenance and replacement parts may be purchased directly from www.PrimalRC.com.

If you are prepared to assemble the truck, visit our website and view the installation videos.

See instruction video on www.PrimalRC.com/Video/TruckInstructions

Then follow along the instructions provided below. If you do not feel comfortable completing the assembly below. STOP. Do not use the truck. Contact us and we can discuss the concerns with you on the phone or by email.

This truck is intended for users that have extensive experience with gas R/C vehicles and 2-Stroke engines.

1. Position main frame and axles on a surface with enough clearance for assembly.
2. Install the brake rotor on the driveshaft and install the drive shaft pin through the drive shaft and pinion gear shaft.
3. Slide the drive shaft from the axle into the drive shaft coming out of the transmission. Make sure the brake rotor is installed on the axle.
4. Attach the axle to the four links already assembled on the main chassis.
5. Install shocks on the main chassis and axles. Note: hardware is already installed on axles and chassis.
6. Connect the two servo wires to the wires coming out of the receiver box. There is no preference for left or right servos – either servo can go into either plug.
7. Attach top sway bar links to already installed sway bar on the chassis. Then attach lower sway bar links to the axle.
8. Install the brake calipers with one pad on each side of rotor (see diagram assembly instructions #68).

Note: The two bolts that hold the brake pads to the caliper should be installed using RED lock tight at the right position. Without lock tight, these screws will come undone very easily.

10. Install the brake cables (see diagram assembly instructions #68). Make sure to route cables as smoothly as possible for ease of operation. Cables should not be bent sharply. Zip-tie cable in strategic location to avoid snagging during operation. Ensure suspension can travel smoothly without pulling on brake cable. See instruction video on www.primalrc.com/video/TruckInstructions.

11. Initial brake cable adjustment: First, ensure your throttle servo is working properly and giving full throttle to carburetor. Then in neutral (i.e. your throttle is not being applied) slide the brake cables into the brake servo cable splitter. Adjust the stop collars so that the breaks are about to apply as soon as you trigger the transmitter to brake position. This adjustment is something that you will fine tune to your needs. Front and rear bias can also be adjusted at the same time.

See instruction video on www.PrimalRC.com/Video/TruckInstructions.

12. Install wheels using supplied lug wrench. The hex nuts have a serrated side, ensure it is facing the rim.
13. Remove protective body film, then install stickers on the body.

See instruction video on www.PrimalRC.com/Video/TruckInstructions.

14. Charge the battery with included charger.
15. Install batteries into transmitter.
16. Follow the instructions in the “Before You Drive”, “Running Your Truck” and “After You Drive” sections of this manual.

Note: Looking at the pictures of the truck on our website can guide you to ensure that you are assembling the truck correctly. Also viewing the instruction videos will give you tips on how to install everything correctly and easily.

Wiring Diagram

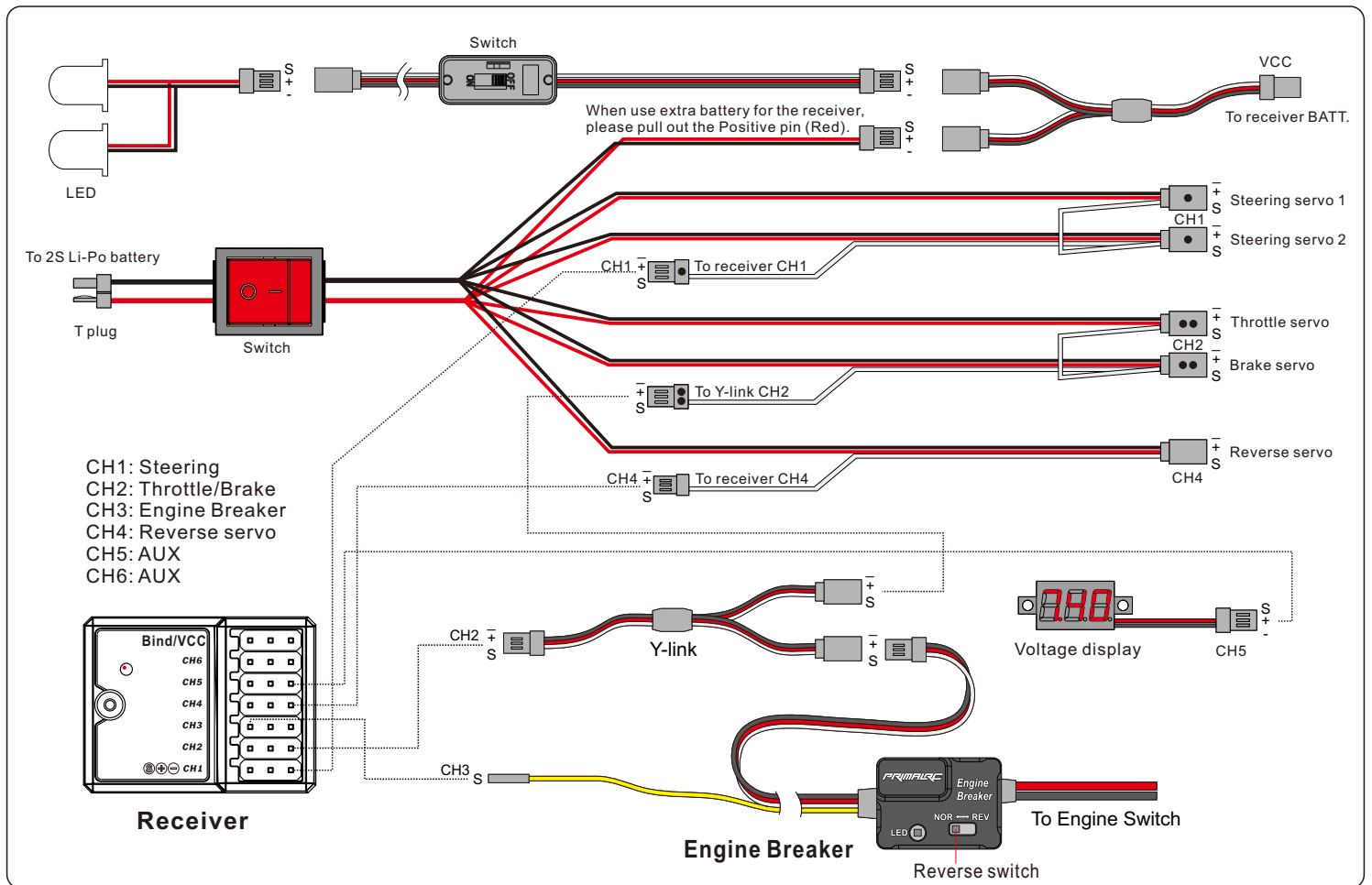

REMOTE ENGINE KILL-SWITCH & FAIL SAFE

Features

1. If receiver loses signal, the RED LED will light and engine will cut off. The fail safe will also engage the brakes to stop the vehicle.
2. The engine can manually be cut off by CH3(AUX) from the transmitter. The RED LED will flash.
3. If low battery voltage is detected the RED LED will light and engine will cut off.

Setup

DON'T start the engine yet!

Hold the throttle trigger fully to the brake position and set the brake end point adjustment (EPA) to 100%. The RED LED should light signaling an engine cut-off. If the LED doesn't light, toggle the REVERSE SWITCH and try again. As you setup the receiver's Fail-Saf function, push the throttle trigger to full brake. Once the Fail-Safe function is setup, return the EPA to its original setting. To verify the Fail-Safe function has been correctly set, turn off the transmitter. The RED LED should turn on.

If everything is setup and connected correctly the GREEN LED will light up and you're ready start the engine.

The engine can be manually cut-off at any time by pressing the CH3(AUX) button. The RED LED will blink red when successful.

LED Status Display

LED	Explanation	Engine status
Green	Correct	Can start
Red	Low Battery Voltage or no signal	Cut-off
Red Blinking	CH3(AUX) is on	Cut-off

Radio Details

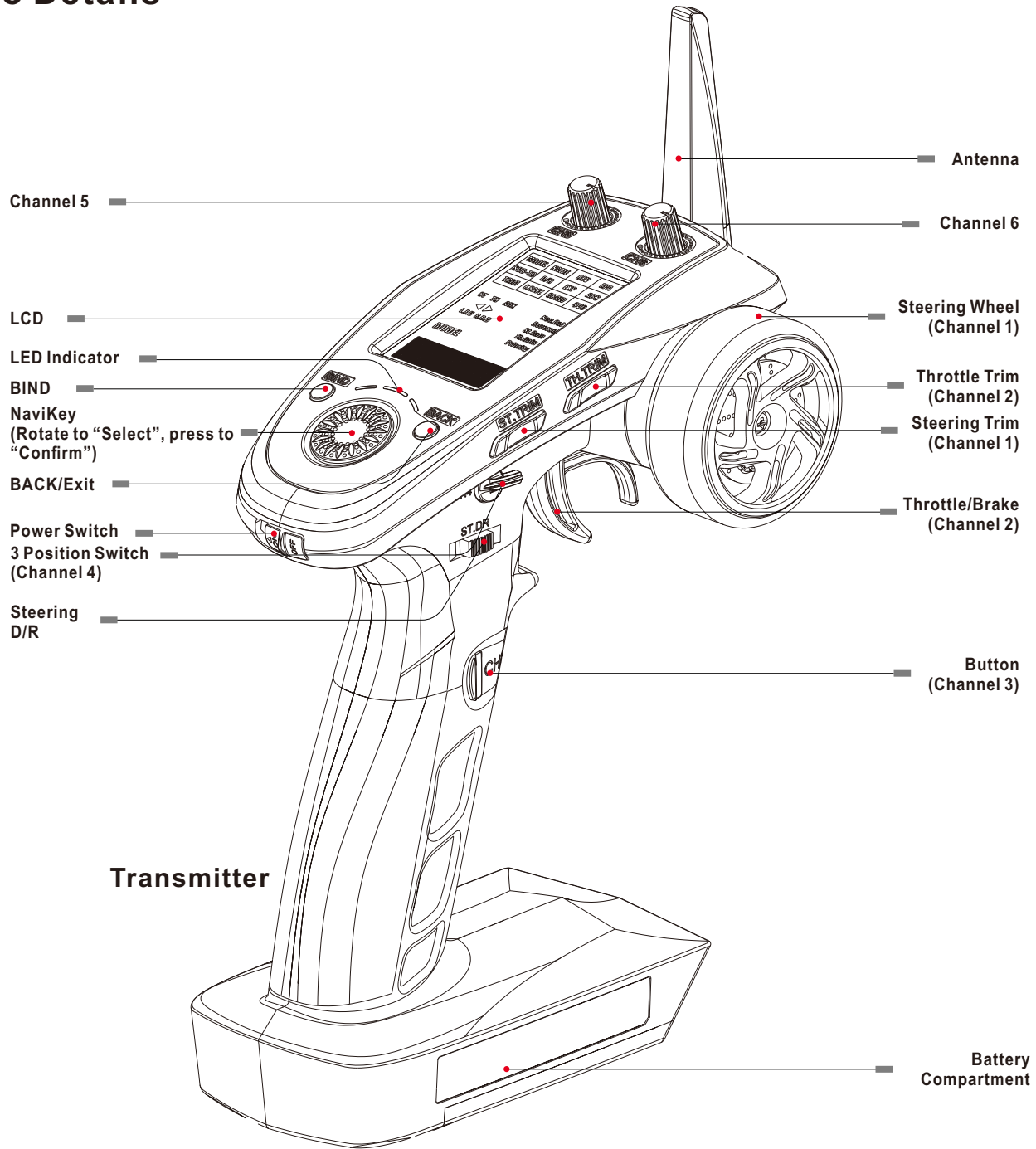

Transmitter

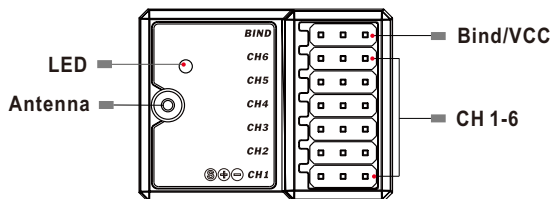

Receiver

Binding setup

The transmitter and receiver have been pre-bound before delivery. If you are using another transmitter or receiver, follow the steps below to bind the transmitter and receiver:

1. Connect the bind cable to the receiver's B/VCC port.
2. Connect power to any other port.
3. Press and hold the transmitter's bind key and turn on the transmitter at the same time.
4. Once binding is complete the transmitter will exit bind mode. Remove the power and bind cable from the receiver then apply power to the B/VCC port.
5. Check to make sure everything functions as expected. If not repeat the steps above.

Before You Drive

It is extremely important that you read, understand, and follow all instructions in the manuals included with this truck in order to prevent serious damage to your truck, yourself, and your property. If the user fails to follow these instructions, it will be considered negligence.

Before assembling and starting your truck, read and understand all manuals and familiarize yourself with the truck completely. If you decide this truck is not the right choice for you or you do not want to assume responsibility for your safety, then do not attempt to start it. Do not run the vehicle at all and please contact us to make arrangements to return your vehicle.

Used vehicles cannot be accepted for returns or exchanges under any circumstances. If you have any questions about your truck, please email us at sales@primalrc.com. Maintenance and replacement parts may be purchased directly from www.PrimalRC.com.

Follow these steps before each drive session:

1. Mix Gas and 2-Stroke Oil
 - Pump gasoline – 87 octane or higher – ethanol-free gas is highly recommended
 - 2-stroke oil. Amsoil Saber (recommended): **Mix 25:1** ratio (gas/oil)
2. Check to make sure you have a fully charged receiver/servo battery in truck.
3. Check to make sure your transmitter batteries are good.
4. Check all servos (Steering, Throttle, Brake, Reverse).
 - **DON'T** start your vehicle's engine yet!
 - Turn your transmitter on.
 - Turn the truck's battery switch on (located in the back of roll cage).
 - Hold the trigger on the transmitter into full brake position. Confirm that the brakes prevent the truck from moving when you try to push it. If it rolls easily adjust brakes as described in the Assembly Instructions section above.
 - Test left and right steering servos by lifting the front of the truck and moving the servos via the transmitter. Ensure the servos are moving smoothly and there is no excessive play or binding. Adjust as necessary.
 - Test throttle servo by giving full throttle and ensure carburetor is moving to full throttle position.
5. Check Remote Engine Kill Switch:
 - **DON'T** start your vehicle's engine yet!
 - Make sure the Manual Engine switch is ON (located on frame under front right wheel well).
 - The Remote Engine Kill switch system is located on the truck near your receiver box and has an LED light. The light is GREEN when it is ready to start and run. If the light is RED this means the Remote Kill switch is on and your engine will not start. Your transmitter's third channel button operates the Remote Kill switch.
 - To test the Remote Kill switch, press the third channel button on the transmitter. The light should turn RED. Press it again to change it back to GREEN before you run the truck.
6. Check the Radio Fail Safe: The radio system that comes with the truck has a fail safe automatically installed ensuring that if your transmitter's signal is not reaching your truck's receiver the brakes will be applied automatically. To test:
 - **DON'T** start your vehicle's engine yet!
 - Turn your transmitter on.
 - Turn the truck's battery switch on (located in the back of roll cage).
 - Turn your transmitter off.
 - Your brake servo should now apply the brake on its own.
 - You have now confirmed that the failsafe is working. Should the receiver lose signal from the transmitter, the brake will automatically be applied.
 - Turn your transmitter back on for normal use.
7. Go over truck to make sure there are no loose screws.
8. Check lug nuts by tightening with provided wrench. Ensure the serrated side of hex nut is facing the rim.

Running Your Truck

1. Add 2-Stroke gas and oil mix to gas tank.
2. Turn your transmitter on.
3. Turn the truck's battery switch on (located in the back of roll cage).
4. Make sure your Manual Engine switch is set to the ON position (located on frame under front right wheel well).
5. Move choke lever to full choke position.
6. Push primer bulb several times, until you see gas going through carburetor and back into gas tank lines.
7. Pull start the engine with a steady, smooth, quick pull until you hear the first pop of the engine trying to start. This is an easy pull start system. There is no need for aggressive, quick pulls. Do not over-extend the pull-start or your pull starter may become damaged.
8. Flip the choke lever to off position (down). Make sure it stays in position.
9. Pull start the engine again with short, quick pulls until your engine starts.
Sometimes a little throttle input from the transmitter may be necessary to start the engine.
Be careful to not give too much gas – it may result in the engine flooding.
10. If you are running the truck for the first time, engine break-in is recommended.
The engine break-in process alternates heating and cooling the engine to allow all parts of engine to properly seat themselves. It also allows 2-stroke oil from the incoming fuel to coat the interior parts of the engine.

Run the engine at varying speeds for periods of 3 to 10 minutes at a time. During this break-in process, never go full throttle.

Try to stay below half throttle. Always let the engine idle for 30 seconds before turning it off. Allow the engine to cool off for 10 minutes before starting it again. Repeat this process 3 or 4 times (3 or 4 full heat cycles).

11. Reverse Driving Instructions

To drive the truck in reverse, **ensure that the truck has come to a complete stop**, then switch channel 4 from the transmitter. Switch to the opposite position – it's a 3-position switch, so be sure to toggle between the furthest positions. This will cause the servo to active the reverse function in the transmission. Test this by giving it a little gas to confirm that reverse is engaged. You may need to toggle the switch ON and OFF again to engage if reverse is not working.

To go back to forward driving repeat the process of **bringing the truck to a stop** and then switching channel 4 to the opposite position.

 **Note:** Because of the size and weight of the truck, try to avoid steering the truck while it is not moving. This will extend the life of your steering servos.

 **Note:** This truck is not waterproof. Do not submerge this truck in deep water. Small puddles or shallow water should not be a problem.

 **Note:** If you are planning on driving this truck in excessive dirt, we recommend that you remove the installed choke. Follow the Choke Removal Instructions in this manual. It might be more difficult to start the truck without the choke, however, your engine will last longer because this choke system can let dirt into your engine.

 **Note:** Using a 2S LiPo battery is possible and will provide better steering power, however, the large current will shorten the life span of the smaller throttle and reverse servos. If you use a LiPo battery, we recommend that you upgrade the throttle and reverse servos to high-voltage servos.

After You Drive

- Be sure to let the engine idle for 30 seconds to cool before stopping the engine.
- Press the Kill Switch button (channel 3) on your transmitter to shut the engine off.
- Turn battery switch OFF (located in the back of roll cage).
- Turn your transmitter OFF.

 **VERY IMPORTANT: ALWAYS** turn off the truck first, then the receiver, then the transmitter in that order. If your receiver or battery switch is left ON and your transmitter is OFF the failsafe will cause the servos to overheat and eventually burn out.

• If your truck is wet or dirty, we recommend rinsing the dirt off with a gentle stream of water and then using compressed air to dry it off.

 **Important!** Lubricate joint areas and moving parts with WD40 to prevent rust and keep truck working properly for many years to come.

(example: wheel bearings, suspension links, drive shafts, servo cables)

• Inspect the truck for loose screws, broken and missing parts. We recommend blue lock-tight for screws that are threaded into aluminum parts that do not have nylon lock nuts.

• If you are storing your truck your truck for a month or more, we recommend draining the gas out of the tank and carburetor.

Love your truck by taking good care of it and it will love you back.

Choke Removal Instructions (optional)

- Watch the instruction video at www.PrimalRC.com/Video/TruckInstructions.
- Loosen air filter clamp and slide air filter off.
- Remove the two screws that are holding the choke system onto the carburetor. To prevent the carburetor from falling off while you remove the screws, hold the carburetor in place.
- Remove the choke plate and lever system and reinstall the velocity stack directly onto the carburetor using the same two screws that you removed earlier, but install 2 additional lock washers on each bolt to act as spacers and allow for proper tightening.
- Reinstall the air filter and tighten the clamp.

Steering Servo Saver Adjustments

The steering system has both servos linked to an adjustable centralized servo saver system. This system helps keep the servos from being damaged when force is put on the front wheels. You can adjust the sensitivity of the system by loosening or tightening the large hex nut on the servo saver spring. Tightening the spring will allow more control of the steering, however the servos will be more vulnerable to damage upon impact. Loosening the spring will reduce steering control, but offer more protection for the servos. Finding the optimal ratio is a matter of personal preference, so test different settings to find one that you prefer.



Brake Adjustments

Watch the instruction video at www.PrimalRC.com/Video/TruckInstructions.

Because the brake system is on the drive shafts, this truck can stop very quickly. If your truck is not stopping quickly brake adjustment is necessary.

This may include changing brake pads and/or rotors, adjusting brake cable tension, and adjusting servo end points. We recommend that you watch our detailed videos online to learn how to adjust your brakes.

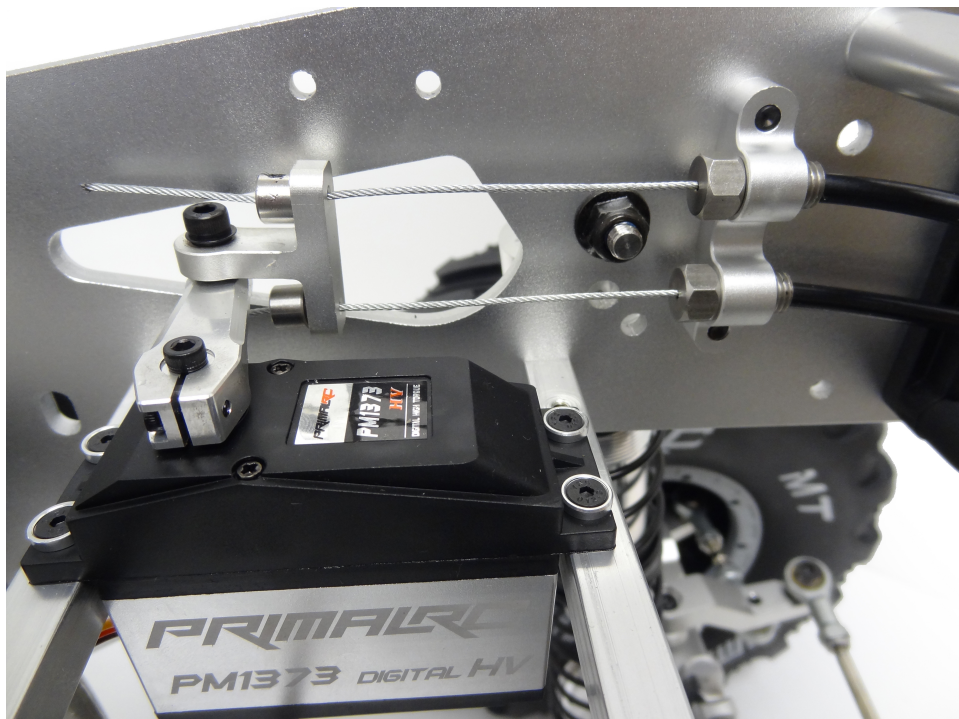
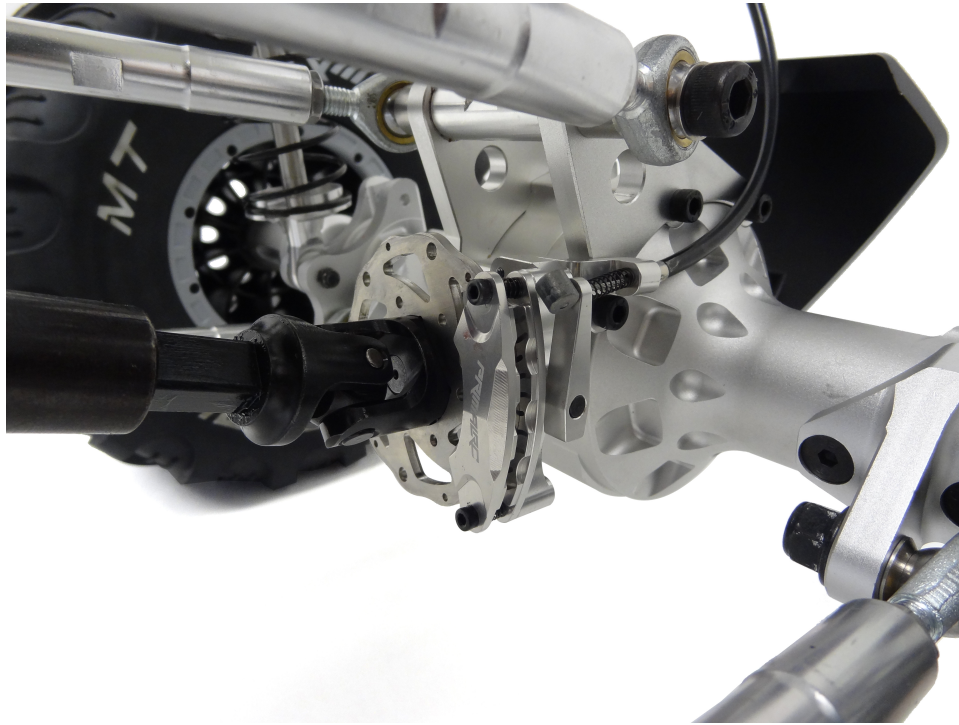

Transmission Gears Adjustment

The truck uses a single-speed transmission that has five different gear ratios to choose from. The mid-range gear set is installed in the truck out-of-the-box (spur/pinion ratio 25:25). Other gear sets that are included with your truck change the driving and power experience. For crawling, we recommend switching to 20:30 or 23:27 ratio. We recommend 27:23 and 30:20 for optional high-performance engines with greater speeds.

The installed ratio is (25:25) is a good overall gear set that we recommend for common use.

To change the gearing in the transmission: (See diagrams #24 and #25 in this instruction manual)

- Remove the rear drive shaft from the rear output shaft of the transmission (a 4mm hex pin holds it in place).
- Remove the six screws (4mm hex) from the transmission case.
- Remove transmission cover and the two ball bearings that hold the gears on.
- Slide off the two gears and install the gear set with your preferred ratio (pinion gear on the left, spur gear on the right which is also transmission output shaft)

Note: Ensure that the gears are greased. You can use the grease that is already in the transmission.

Note: The smaller the pinion gear, the slower the truck will drive, but the more low-speed power it will have.

- Reinstall the two bearings, the cover and the rear drive shaft to their original positions.



Troubleshooting Guide

The engine doesn't start or is not running well

- o Make sure your gas and oil are mixed properly.
 - Mix Gas and 2-Stroke Oil
 - Pump gasoline – 87 octane or higher – ethanol-free gas is highly recommended
 - 2-stroke oil. Amsoil Saber (recommended)
 - Mixed 25:1 ratio (gas/oil)
- o Follow the instructions in this manual for “Running Your Truck”. If your truck still does not start, try the following:
 - Check to make sure your spark plug is clean and working. Remove the plug from the engine and inspect the tip. If it is clogged, it will need to be cleaned or replaced. After the plug is removed, check if the plug is working by:
 - o Attaching the wire to the top of the plug
 - o Placing the tip of the plug very close to the metal of the cylinder.
 - o Pull the pull start a few times. A spark should jump from the plug to the cylinder. If no spark or a weak spark is observed, replace the plug, ensure the ignition coil and flywheel are properly gapped, then check again.
 - o If still no spark - you likely have a problem with the ignition coil and will need to replace it.
 - The Remote Kill Switch may not be working properly and will need to be tested.
 - Check to make sure your carburetor is properly tuned. You may need to adjust the screw slightly in either direction to find correct tuning for your carb.
 - o **Stock carb setting is 5 full turns out** from snug. This is a rich setting meant for break in, but it's a good base setting. Around 4 turns out is the usual setting for a broken in stock engine.
 - Your engine may be flooded. This can happen if you have pushed the primer bulb many times, or pulled the pull start a lot of times.
 - o Remove the spark plug and allow all the fuel in the cylinder to evaporate.
 - Your compression may be bad. If you have an older engine, the piston rings may need replacement.
 - Check your carb gasket, intake gasket, cylinder gasket, and crankcase gasket. Can you hear air whooshing out of the cylinder gasket or crankcase gasket when you pull the starter? Is air leaking in the manifold gasket behind the carb?
 - o A gasket leak results in a loss of compression and/or improperly mixed fuel and air. An easy way to check for intake leaks is to spray the intake manifold and area surrounding it with WD-40. If the idle changes after you spray the WD-40, there is an intake air leak.
 - o Common areas for leaks are between the manifold and the cylinder, and between the carb and the intake manifold. Inspect the manifold, carb gasket, and intake gasket for cracks or other signs of damage, replace if necessary.
 - Make sure your gas cap is venting properly. There should be a small hole in the plastic cap and bladder. If it becomes blocked or clogged it can cause issues. Also check to make sure fuel lines are connected correctly, the fuel lines aren't cut, and the fuel filter is attached.
 - Make sure there is no debris (grass/dirt/etc.) clogging the pull start, air filter or engine. This can result in the engine running too hot and becoming overheated.

Troubleshooting Guide (continued)

The engine doesn't idle well

- o If the idle is too low, turn the carburetor idle screw clockwise to raise idle. If the idle is too high turn it counterclockwise until the desired idle is reached. Idling as low as possible is recommended without the engine stalling. The clutch may start to engage, preventing the reverse function from working properly.

The servos aren't responding, or the transmitter is not connecting

- o Check that transmitter switch is on
- o Check that truck's battery switch is on
- o Check the wire connections. Make sure they're intact and connected properly.
- o Check that your batteries are charged
- o Check to make sure your transmitter and receiver are bound.

The servos aren't moving in correct direction

- o Check servo reverse functions on the transmitter.

The brakes are not working, but the brake servos are moving

- o Adjust cable wire to ensure that the brake is pulling properly on the calipers.
- o Check to make sure brake pads are not worn out.
- o Check that drive line axle pins and driveshaft pins are not broken.

Reverse is not working

- o Make sure you stop the truck from rolling before switching to reverse.
- o Check that your idle is low. If idle is too high, The clutch may start to engage, preventing the reverse function from working properly.
- o Adjust the reverse servo cable to ensure that it is pulling enough to engage reverse properly.

1 Differential Assembly

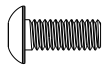

MBS4010
M4×10mm ×4

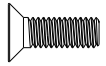

MFS4012
M4×12mm ×8

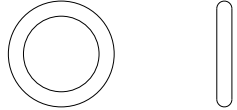

ORS14020
O-Ring D14×2mm ×4



BBS101504
Bearing 10×15×4mm ×8

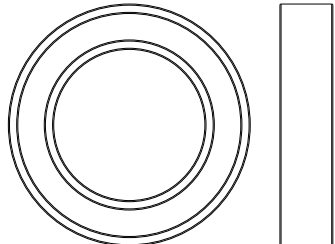

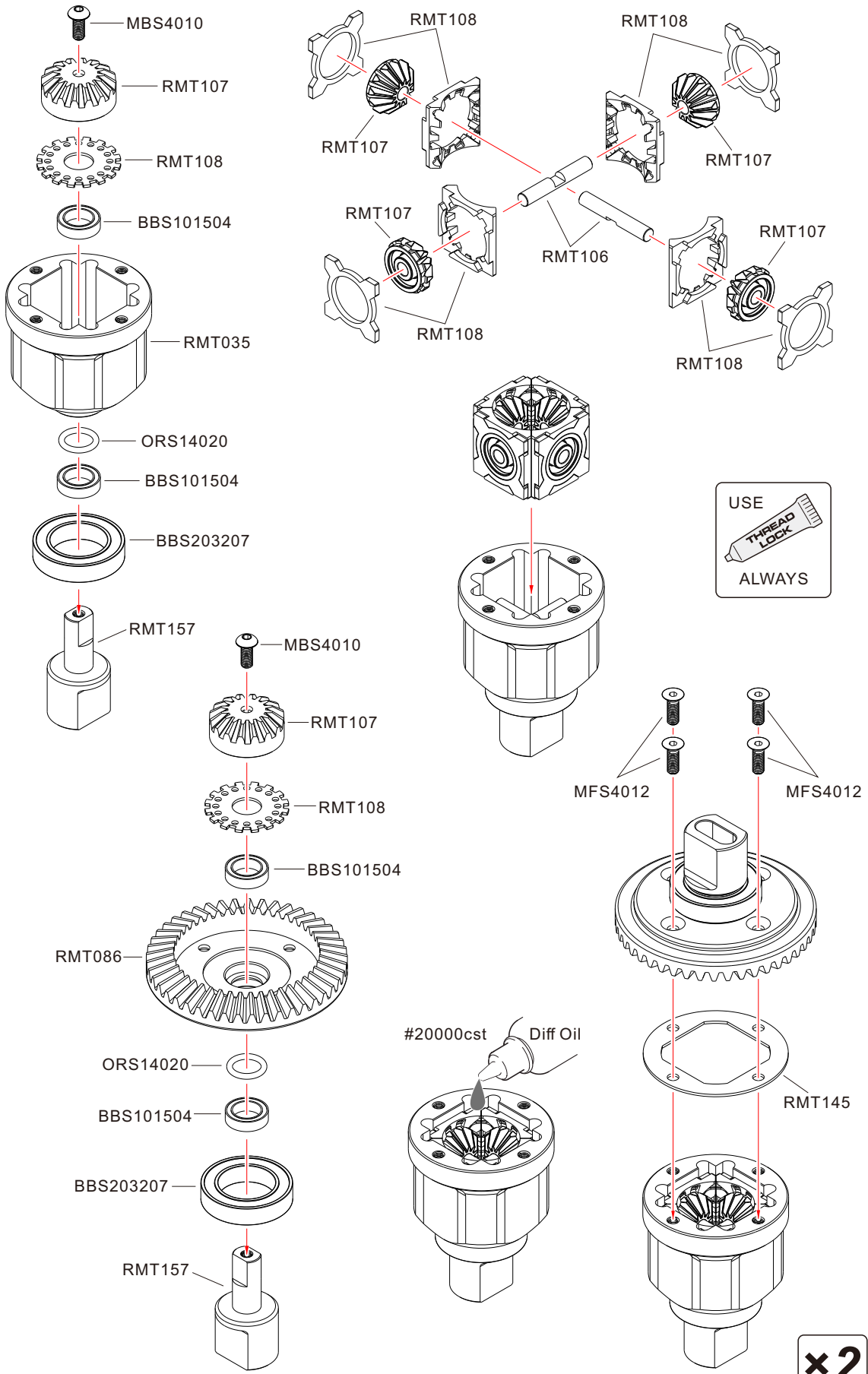

BBS203207
Bearing 20×32×7mm ×4



USE
THREAD LOCK
ALWAYS

×2

2 Front Axle Assembly

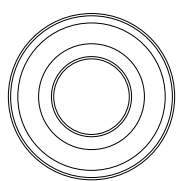
-  MCS4020 M4x20mm **x2**
-  MCS5040 M5x40mm **x7**
-  BBS102206 Bearing 10x22x6mm **x2**

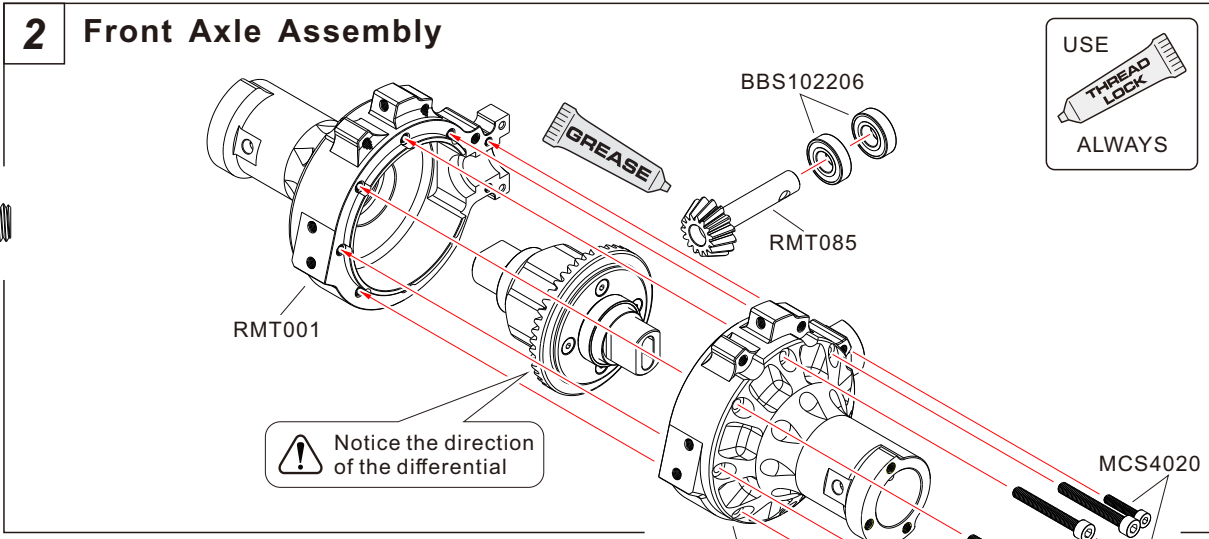

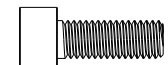
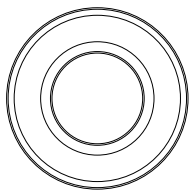

3

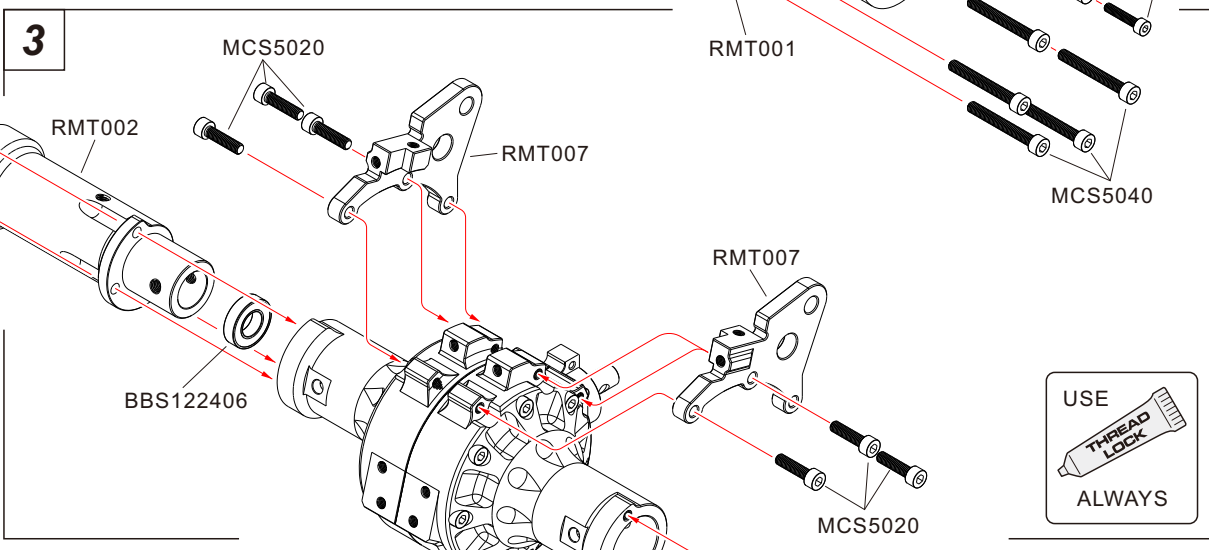
-  MCS5014 M5x14mm **x6**
-  BBS122406 Bearing 12x24x6mm **x4**



4

-  MCS5016 M5x16mm **x8**
-  MCS5020 M5x20mm **x10**
-  MFS6016 M6x16mm **x8**

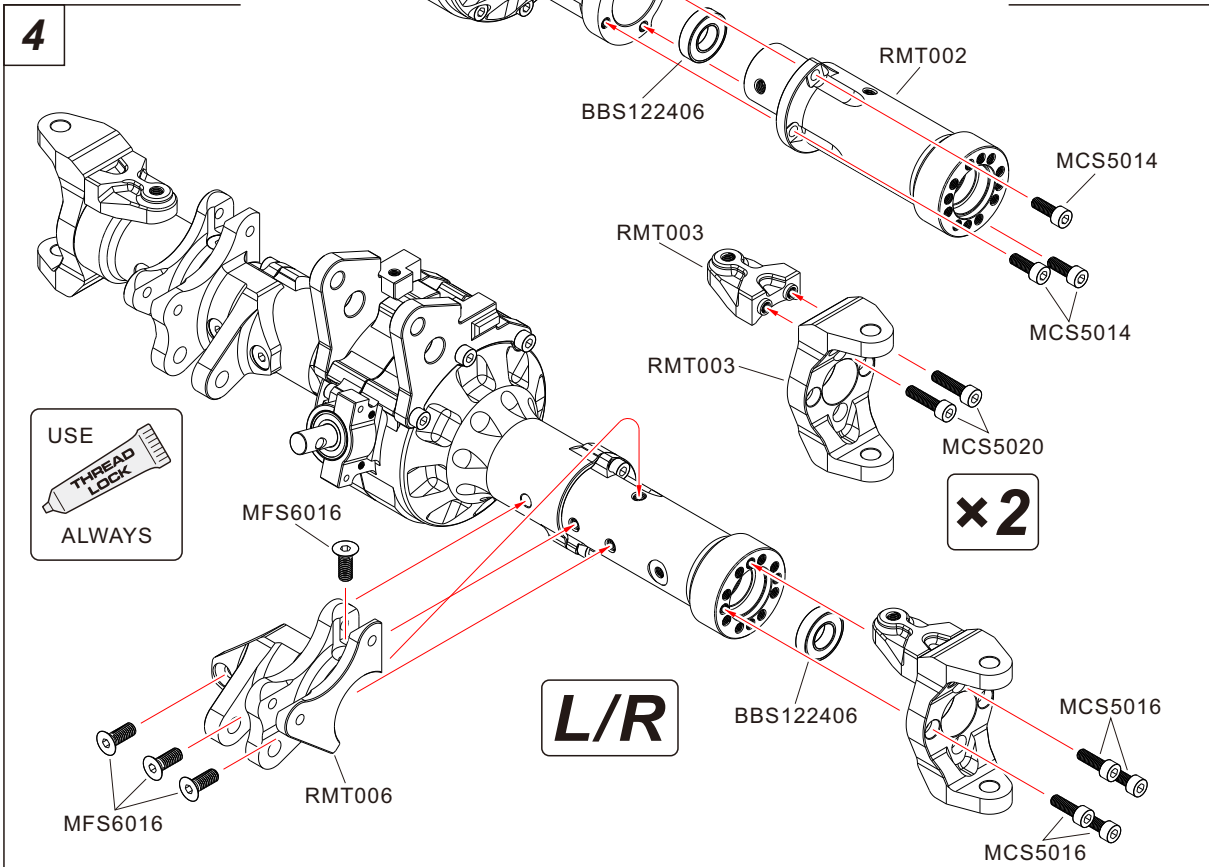

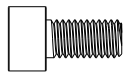

MCS5010
M5×10mm **x2**

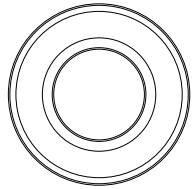

BBS122406
Bearing 12×24×6mm **x2**

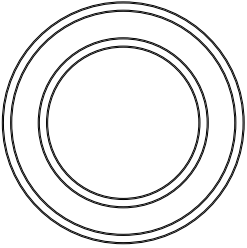

BBS203207
Bearing 20×32×7mm **x2**

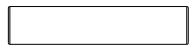

PINS5024
M5×24mm **x2**



MCS6020
M6×20mm **x4**



MBS6020
M6×20mm **x2**



MCS5016
M5×16mm **x1**

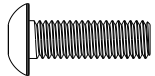

MCS5016
M5×16mm **x2**

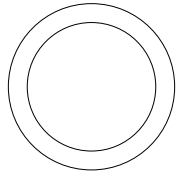

ORS22025
O-Ring D22×2.5mm **x1**

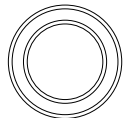

BBS101504
Bearing 10×15×4mm **x2**

5

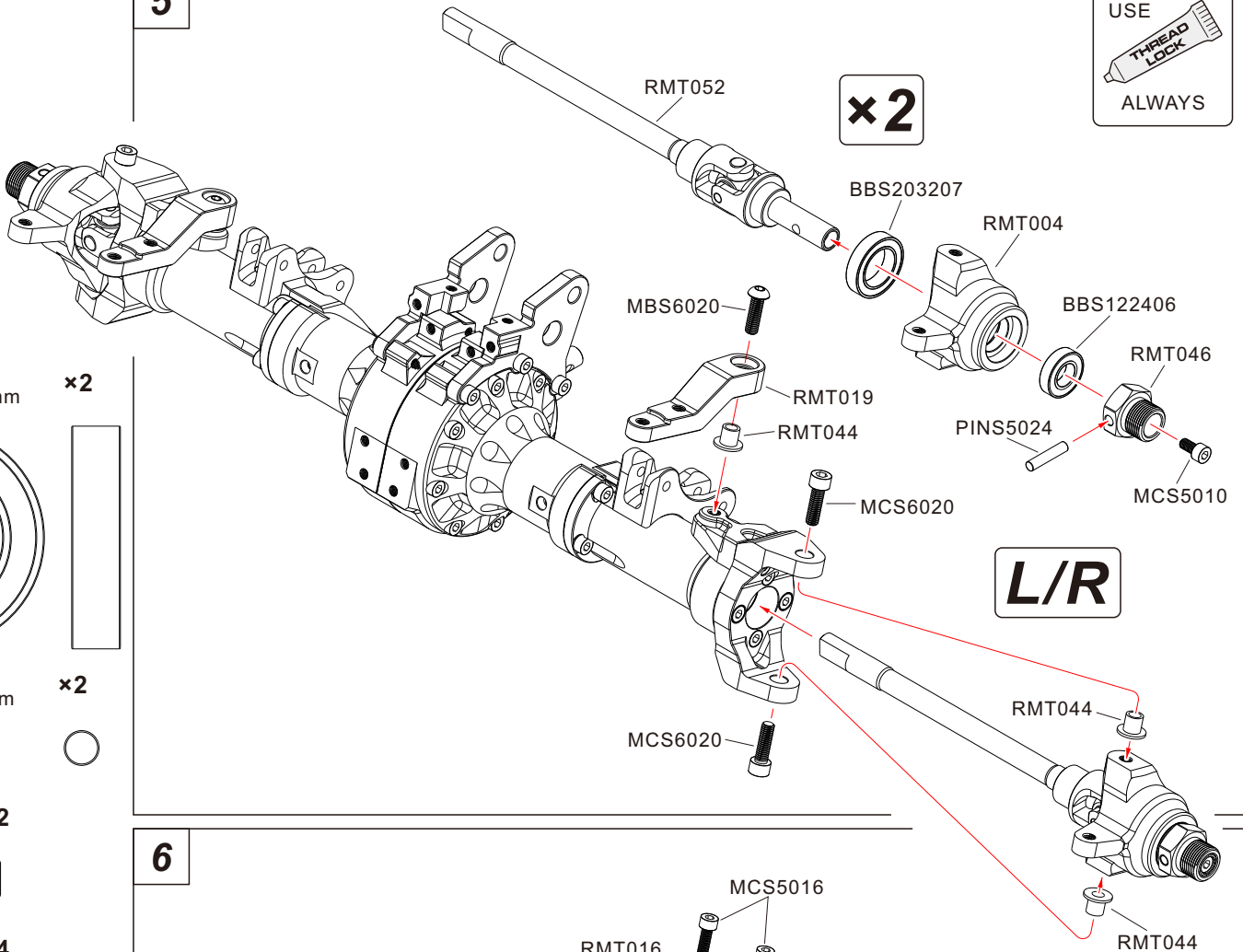

6

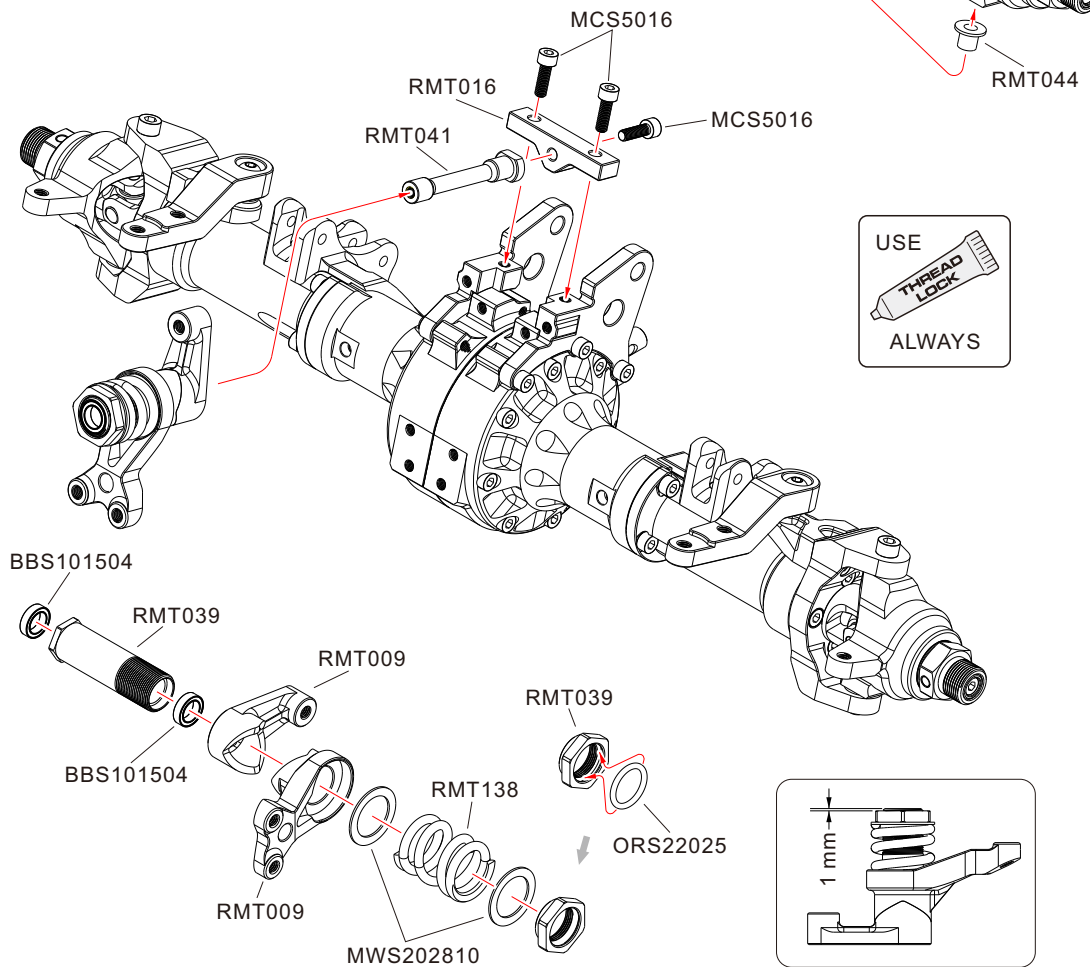



MFS3014
M3×14mm

×8

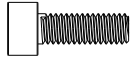

MCS4012
M4×12mm

×4

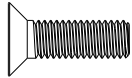

MFS5016
M5×16mm

×4

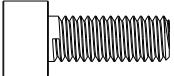

MCS6016
M6×16mm

×2



MWS030810
Washer 3×8×1mm

×8



MCS3008
M3×8mm

×2



MCS3014
M3×14mm

×8



MBS4012
M4×12mm

×2



MBS6040
M6×40mm

×1

7

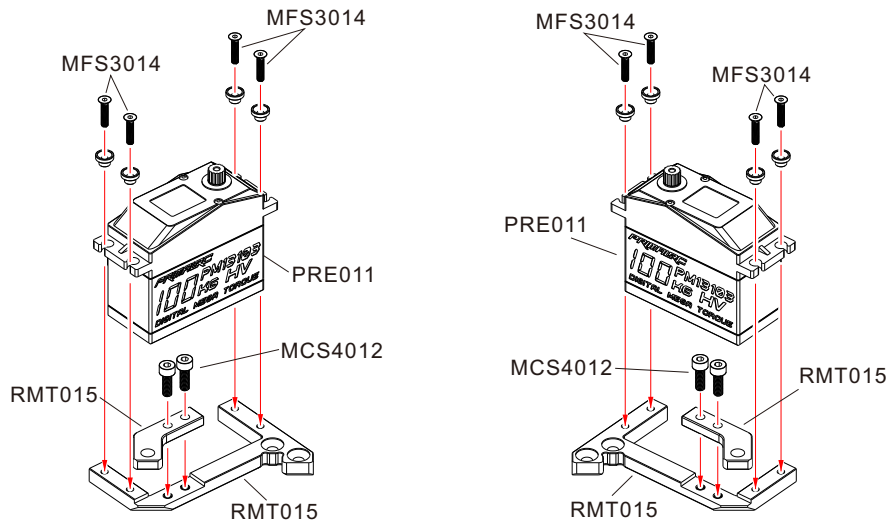

USE
THREAD
LOCK
ALWAYS

8

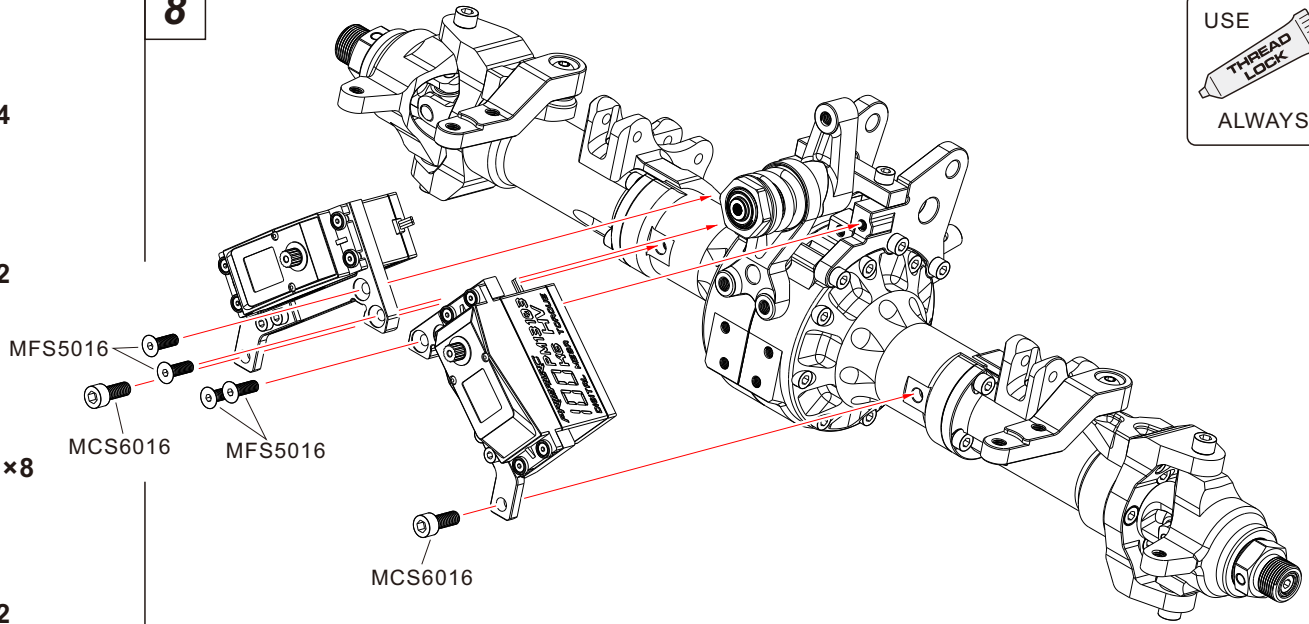

USE
THREAD
LOCK
ALWAYS

9

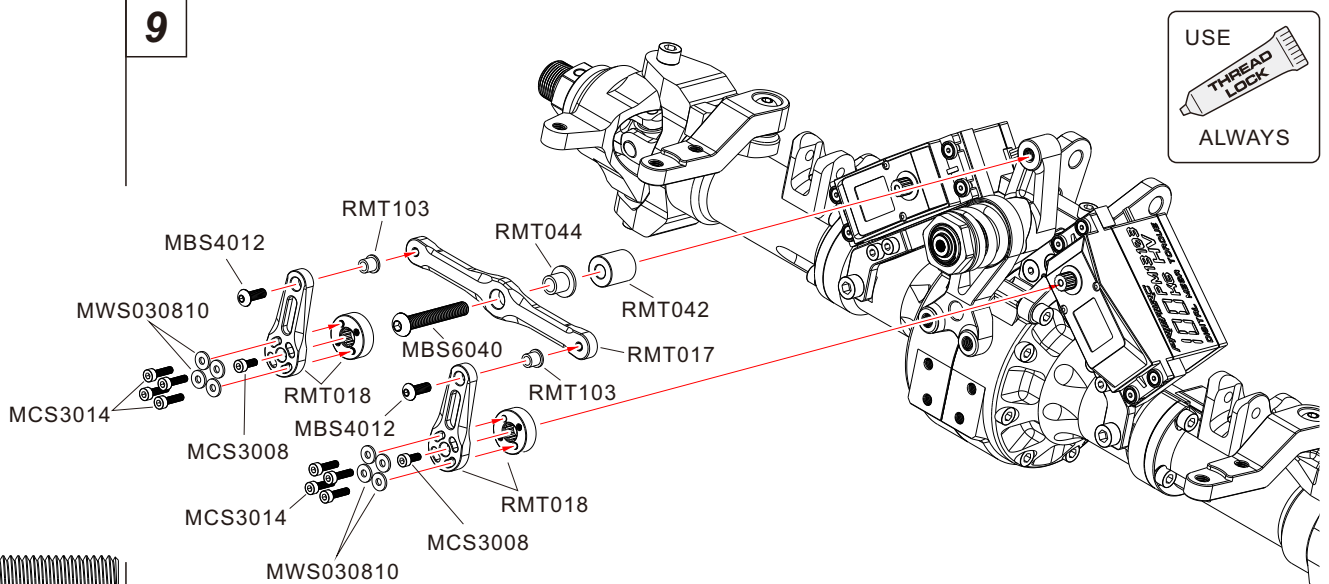

USE
THREAD
LOCK
ALWAYS



MNNS60
M6 Nut

×4



MNRS60
M6 Reverse Nut

×4

10

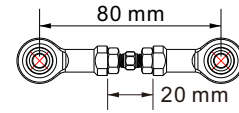
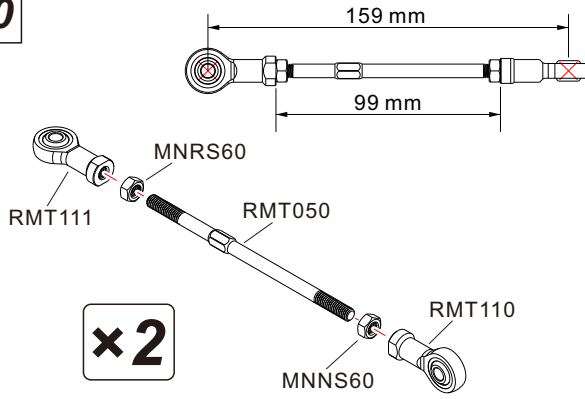

USE
THREAD
LOCK
ALWAYS

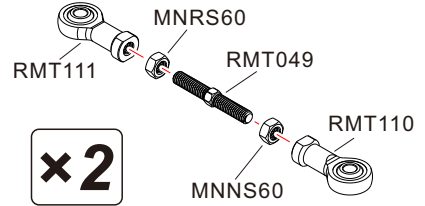

11

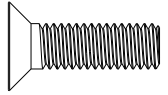

MFS6020
M6×20mm

×2

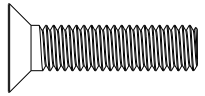

MFS6025
M6×25mm

×6

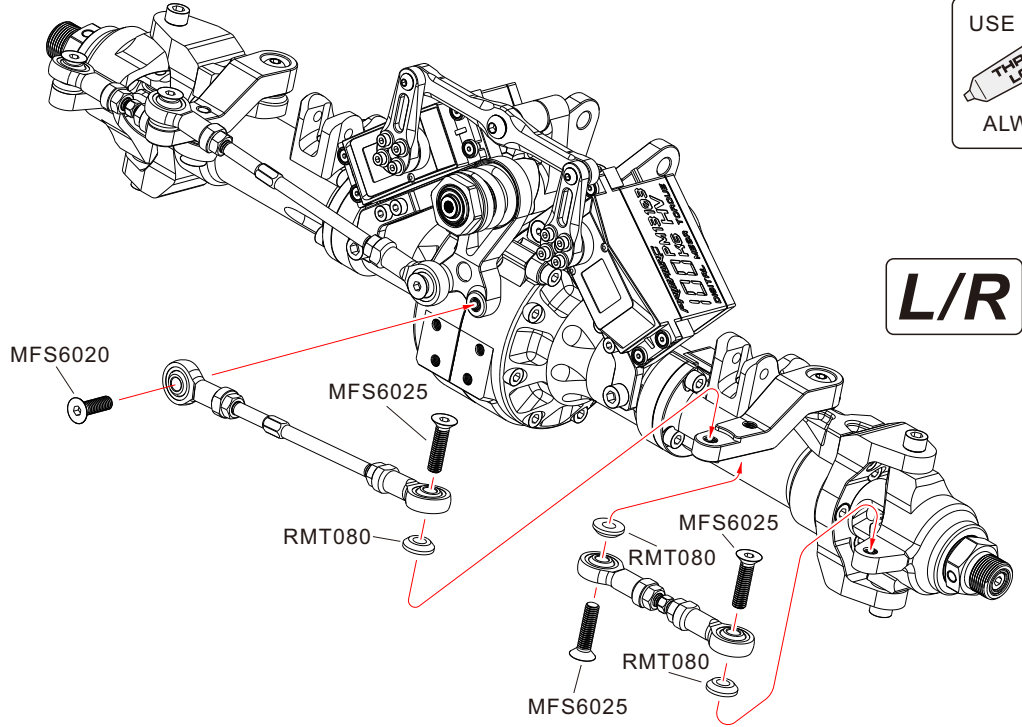

USE
THREAD
LOCK
ALWAYS

L/R

12

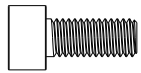

MCS5012
M5×12mm

×1

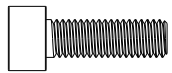

MCS5016
M5×16mm

×4

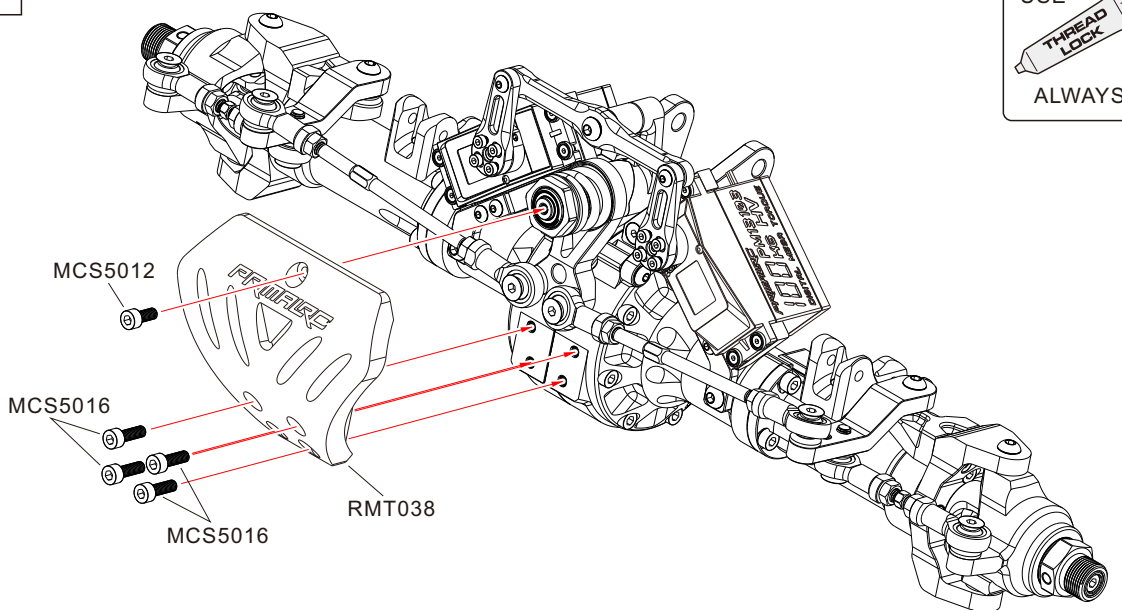

USE
THREAD
LOCK
ALWAYS

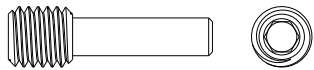

RMT055
M8x27mm x1

13

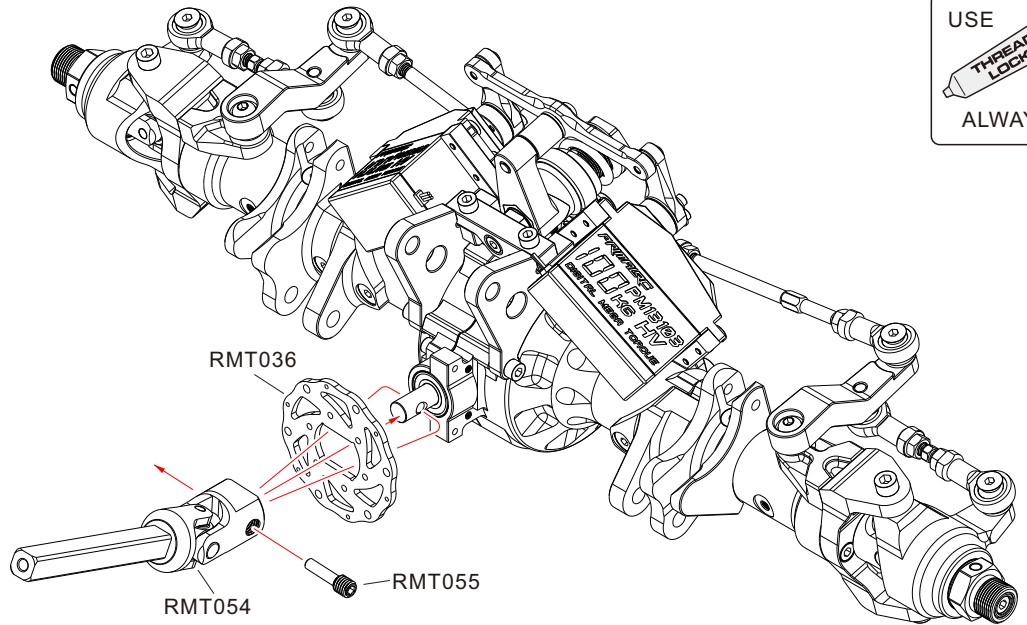

USE
THREAD
LOCK
ALWAYS



MFS3010
M3x10mm x4



MSS4004
M4x4mm x2



MCS3020
M3x20mm x4



BBS050825
Bearing 5x8x2.5mm x4



MES40
E-clip 4mm x2



MCS3020
M3x20mm x2

14

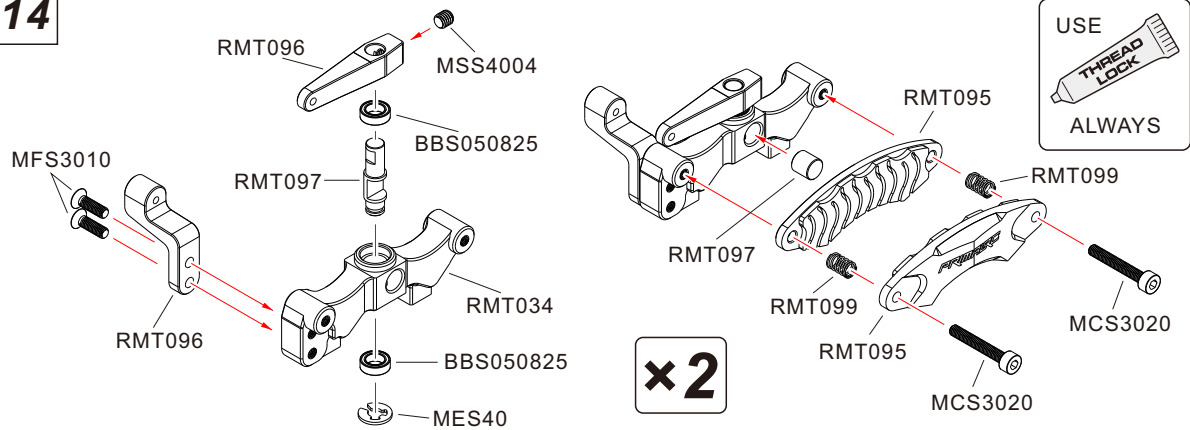

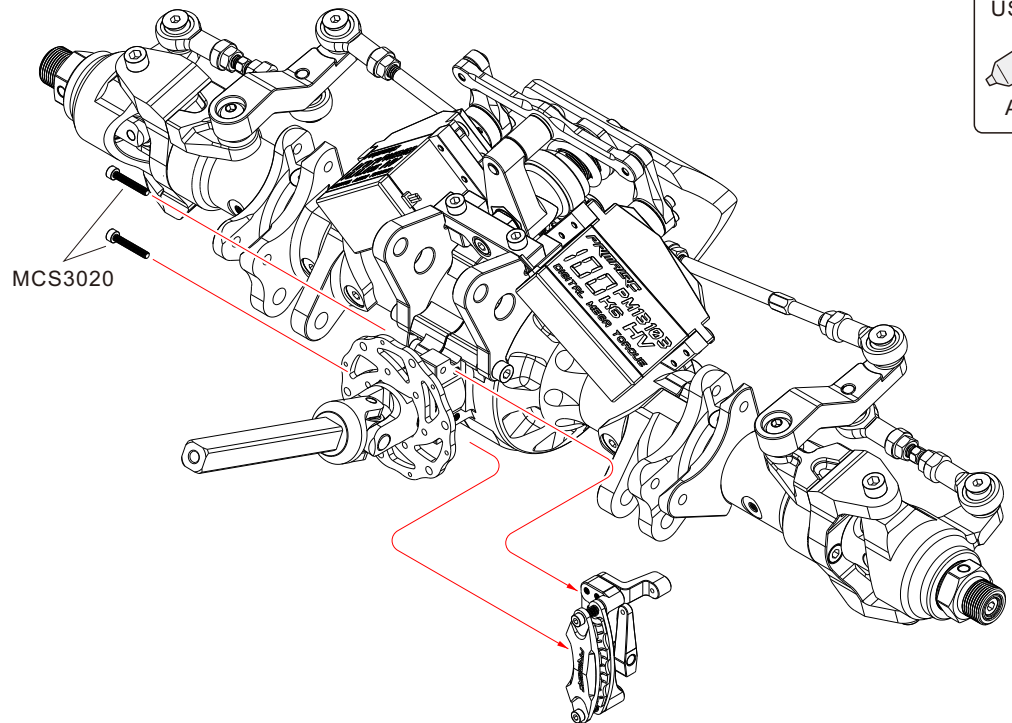

USE
THREAD
LOCK
ALWAYS

15



USE
THREAD
LOCK
ALWAYS

16 Rear Axle Assembly

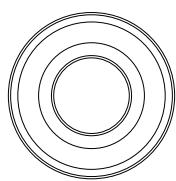
-  MCS4020 M4x20mm **x2**
-  MCS5040 M5x40mm **x7**
-  BBS102206 Bearing 10x22x6mm **x2**

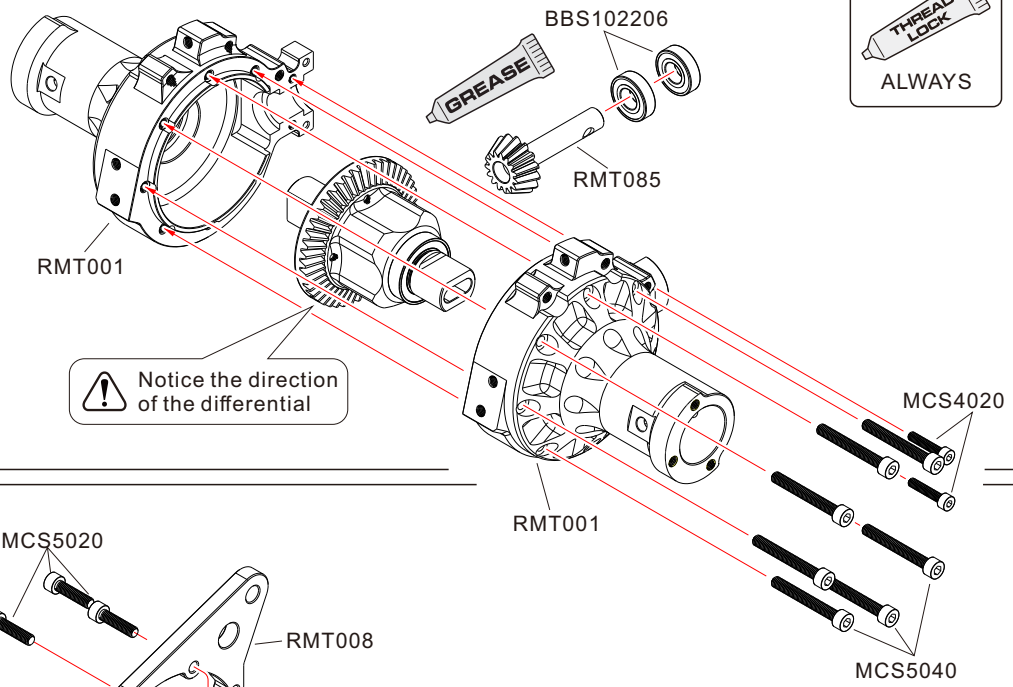

USE

 ALWAYS

17

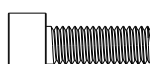
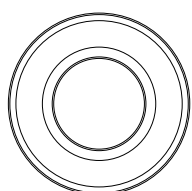

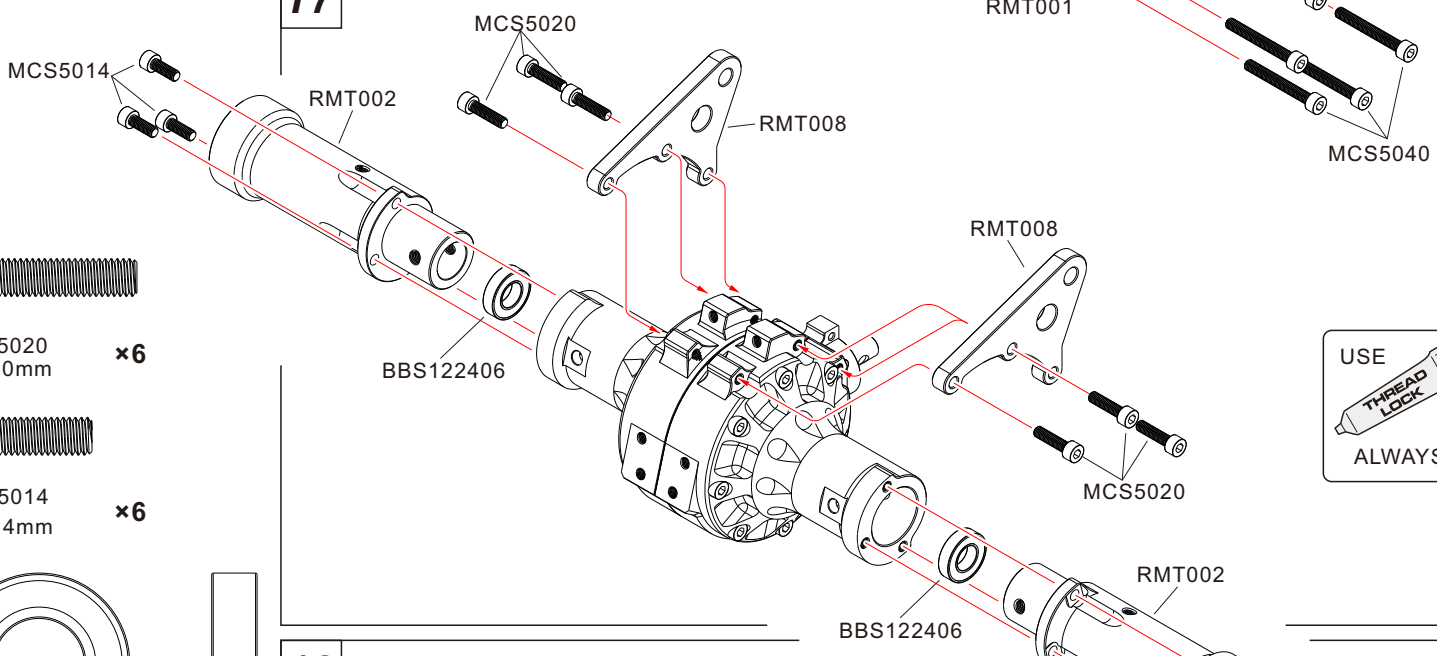
-  MCS5020 M5x20mm **x6**
-  MCS5014 M5x14mm **x6**
-  BBS122406 Bearing 12x24x6mm **x2**



USE

 ALWAYS

18

-  MFS6016 M6x16mm **x8**
-  MCS6010 M6x10mm **x2**

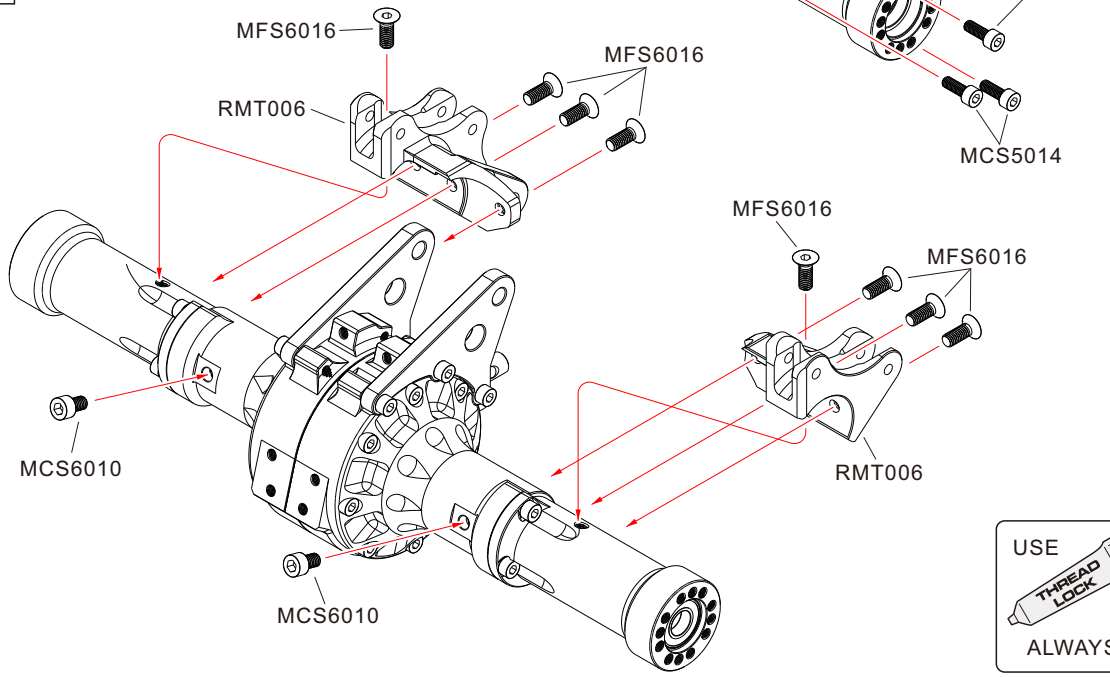

USE

 ALWAYS

19

USE
THREAD
LOCK
ALWAYS

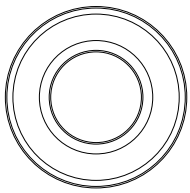

BBS122406
Bearing 12x24x6mm
x4

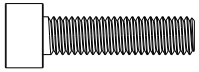

MCS5020
M5x20mm
x8

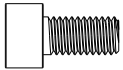

MCS5010
M5x10mm
x2



PINS5024
M5x24mm
x2



MCS5016
M5x16mm
x4

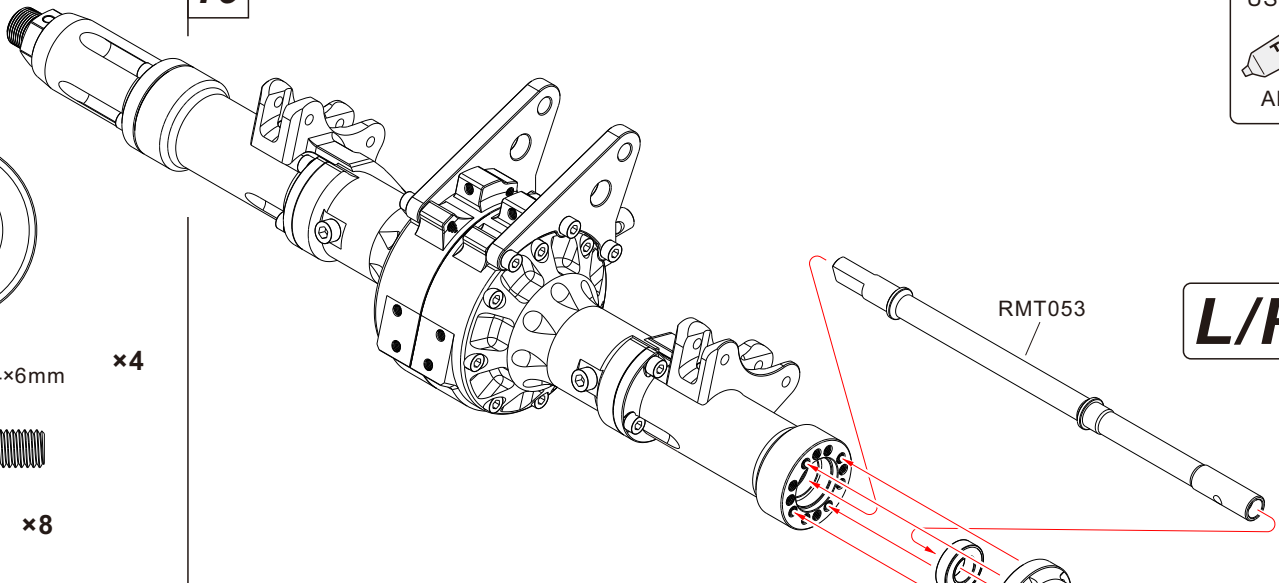

L/R

20

USE
THREAD
LOCK
ALWAYS

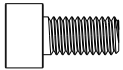

MCS5010
M5x10mm
x2



PINS5024
M5x24mm
x2



MCS5016
M5x16mm
x4

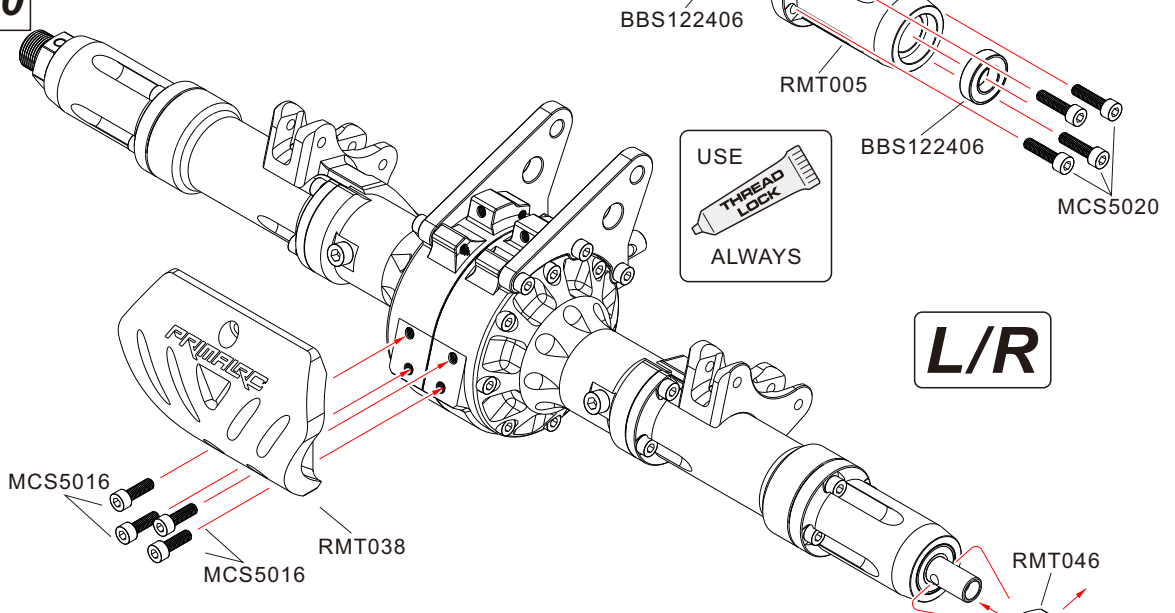

L/R

21

USE
THREAD
LOCK
ALWAYS

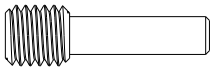

RMT055
M8x27mm
x1

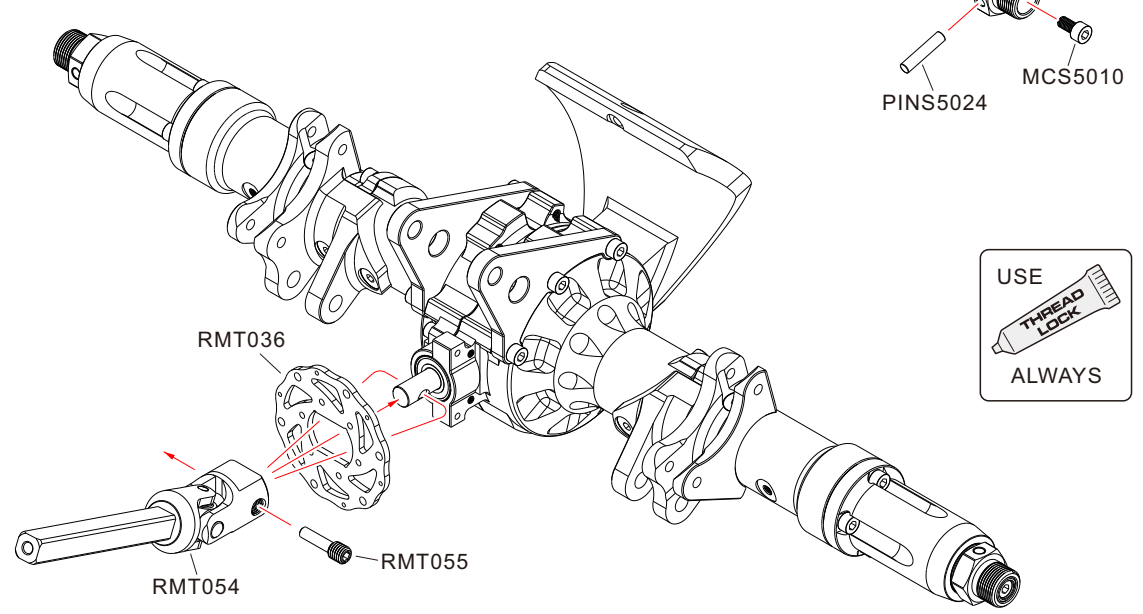



MCS3020
M3×20mm ×2

22

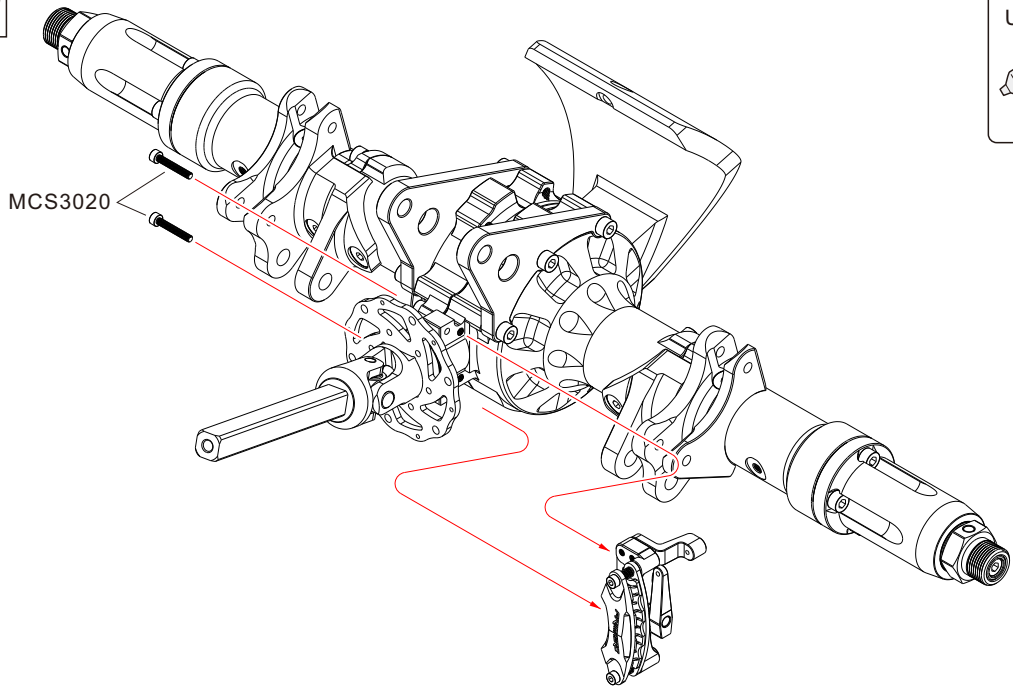

USE
THREAD
LOCK
ALWAYS

23 Reverse Gear Box Assembly



MSS4004
M4×4mm ×1



MSS5005
M5×5mm ×2

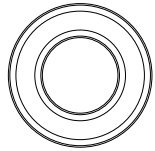

BBS101905
Bearing 10×19×5mm ×4

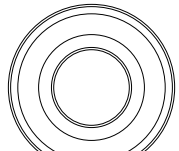

BBS102206
Bearing 10×22×6mm ×1

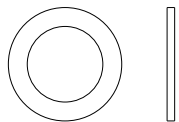

MWS101510
Washer 10×15×1mm ×1

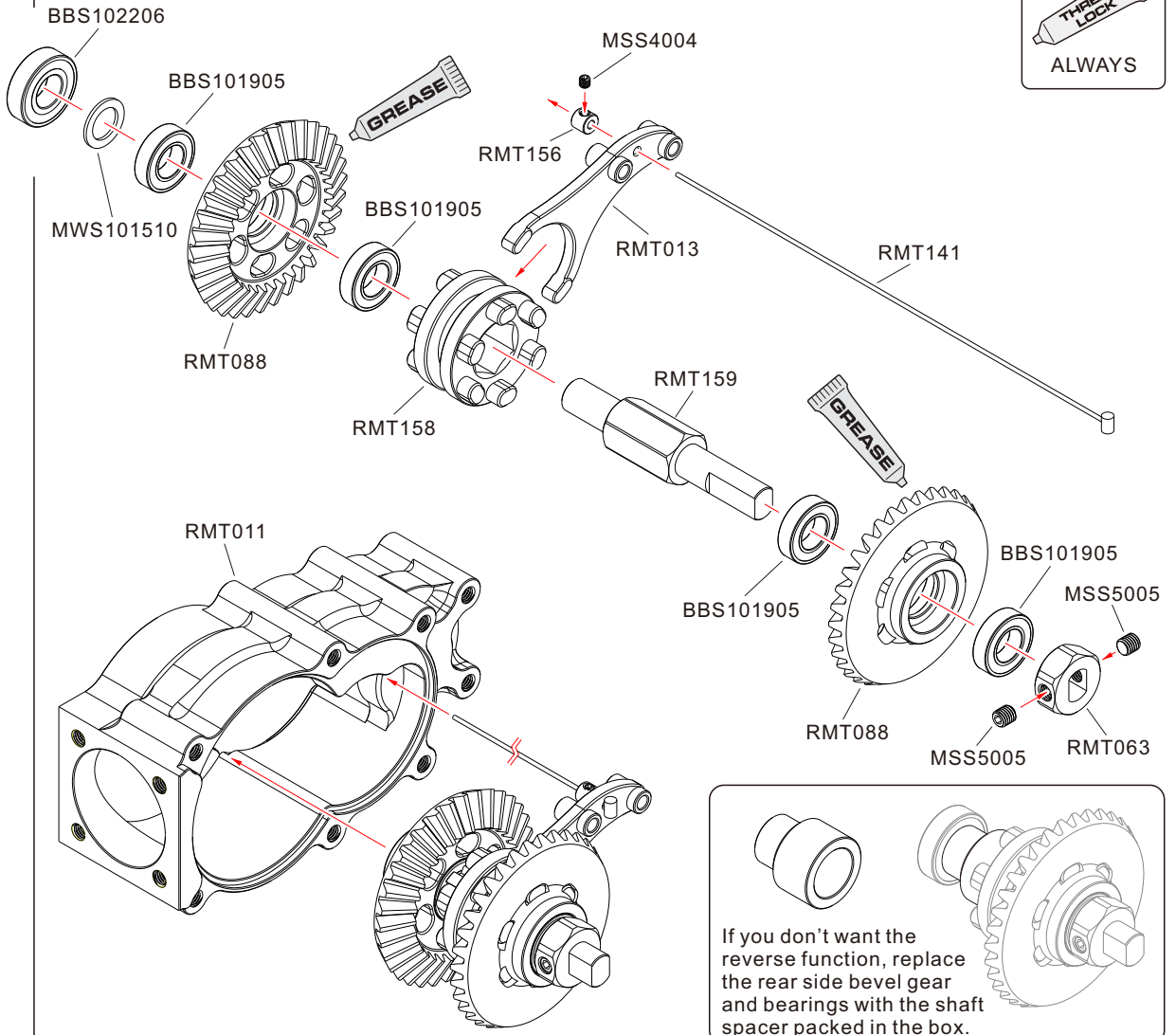

USE
THREAD
LOCK
ALWAYS

If you don't want the reverse function, replace the rear side bevel gear and bearings with the shaft spacer packed in the box.

24

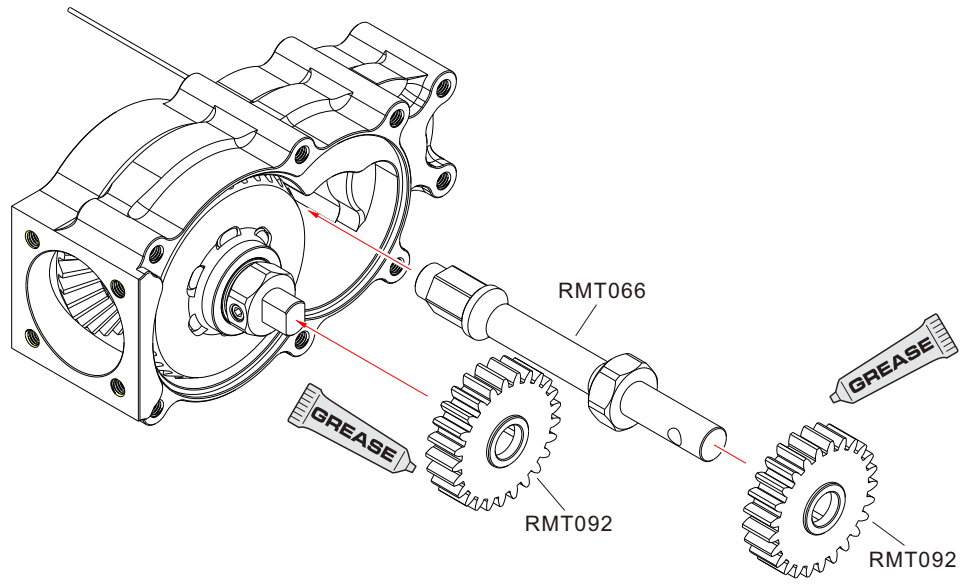

Total Gear Ratio		Spur				
		30	27	25	23	20
Pinion	20	27				
	23		21.13			
	25			18		
	27				15.33	
	30					12

Low speed More torque ← → High speed Less torque

25

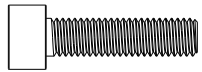

MCS5020
M5×20mm ×6

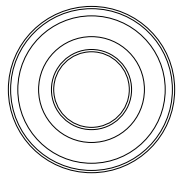

BBS102206
Bearing 10×22×6mm ×2

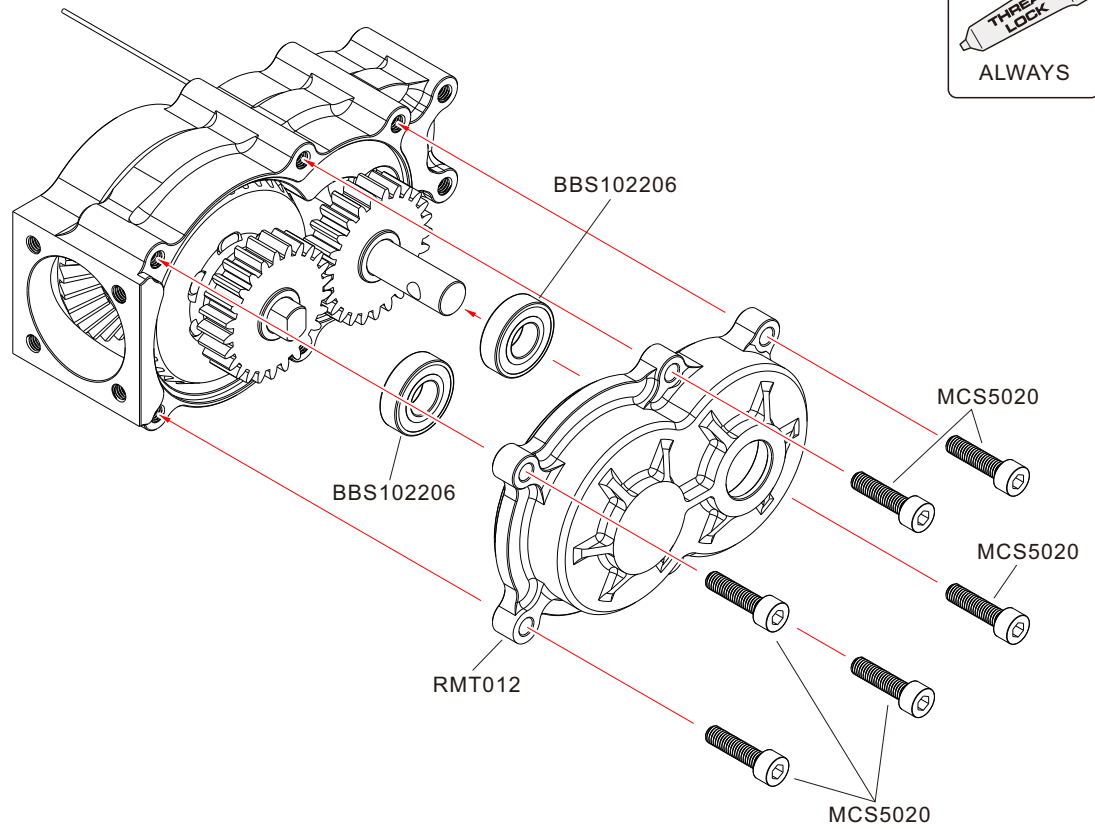

26

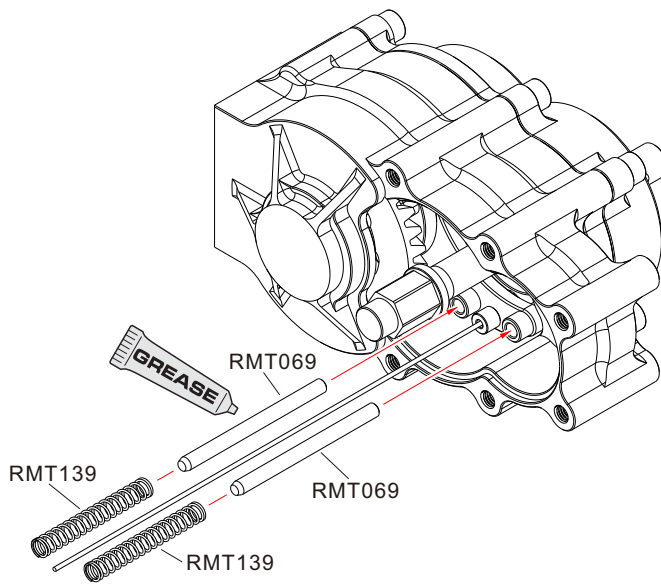

27

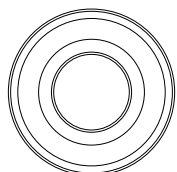

BBS102206
Bearing 10×22×6mm

×1

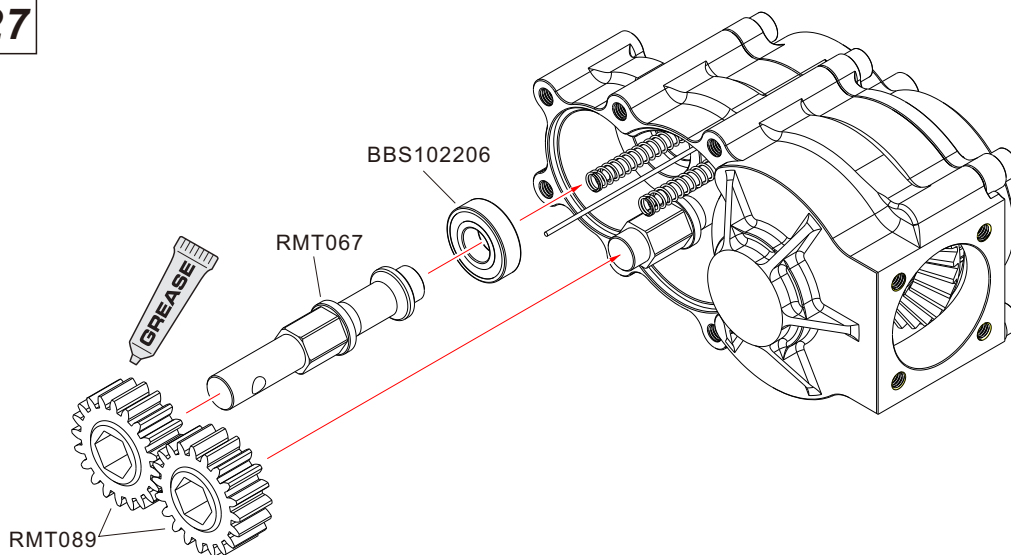

MCS5020
M5×20mm

×6

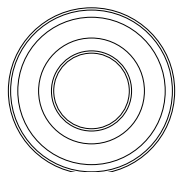

BBS102206
Bearing 10×22×6mm

×2

28

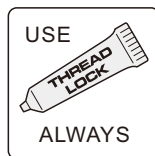
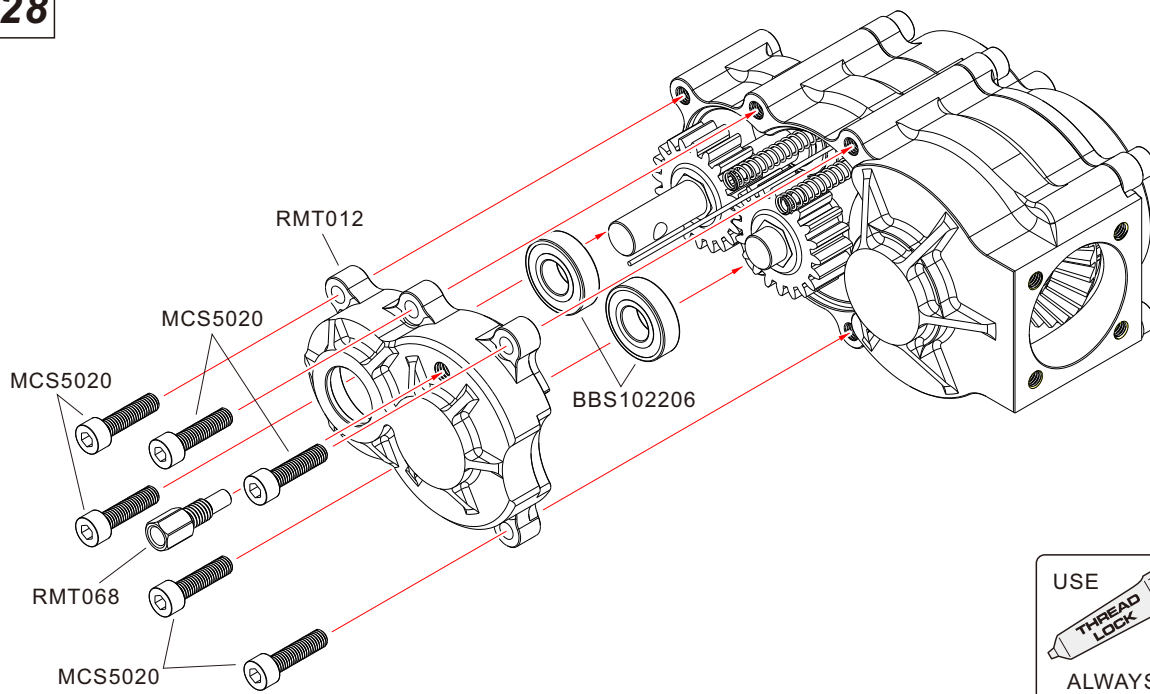



MCS5025
M5x25mm **x1**



MPS50
Spring Washer M5 **x1**

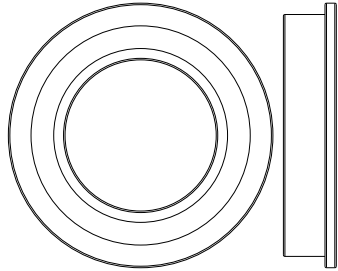

FBS203207
Flange Bearing 20x32x7mm **x1**

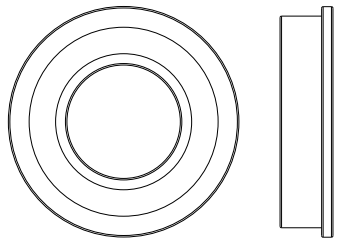

FBS152807
Flange Bearing 15x28x7mm **x1**

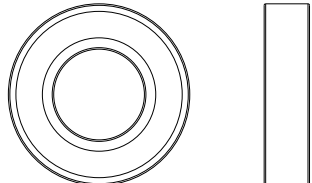

BBS122406
Bearing 12x24x6mm **x1**

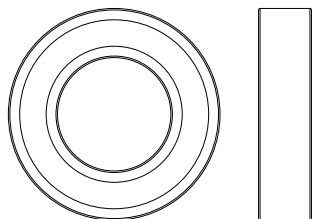

BBS152807
Bearing 15x28x7mm **x1**

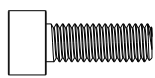

MCS5014
M5x14mm **x4**

29

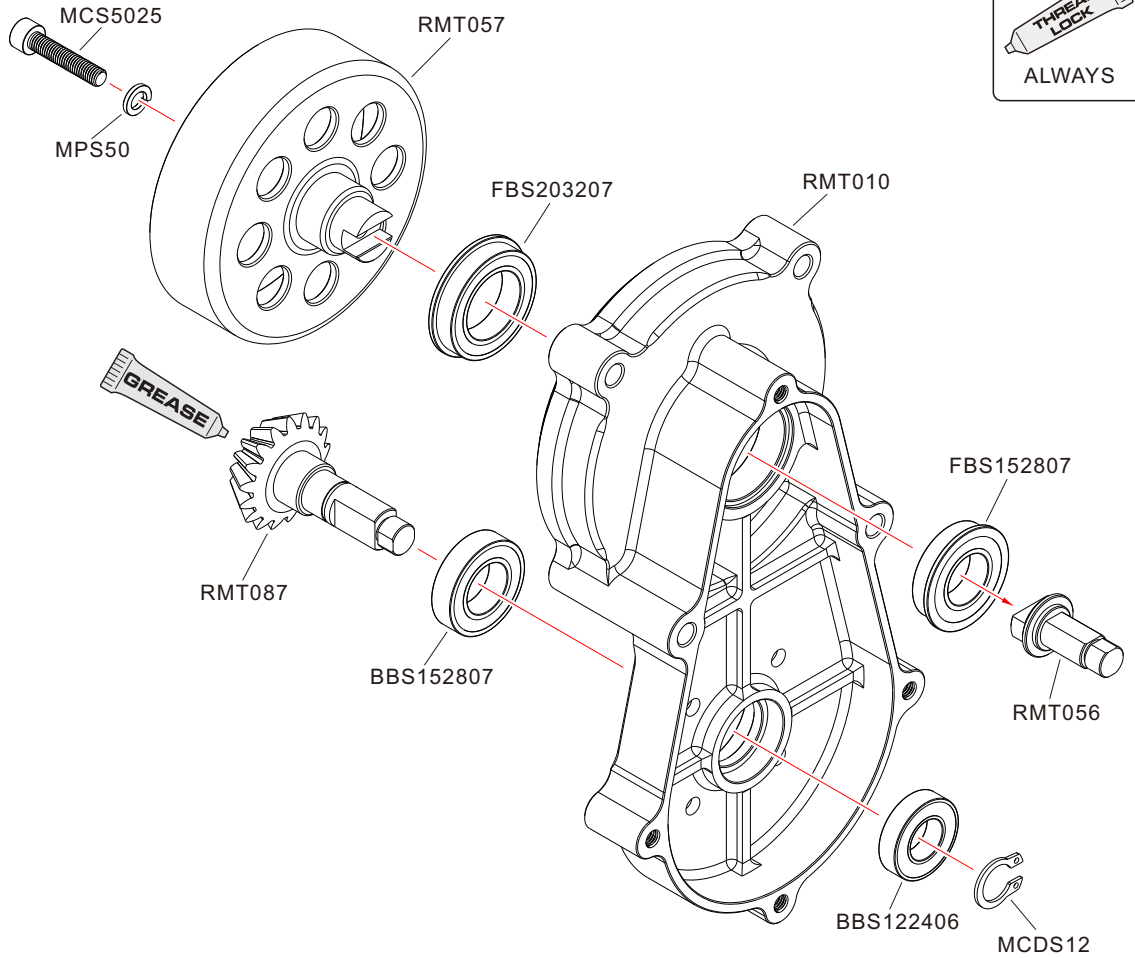

USE
**THREAD
LOCK**
ALWAYS

30

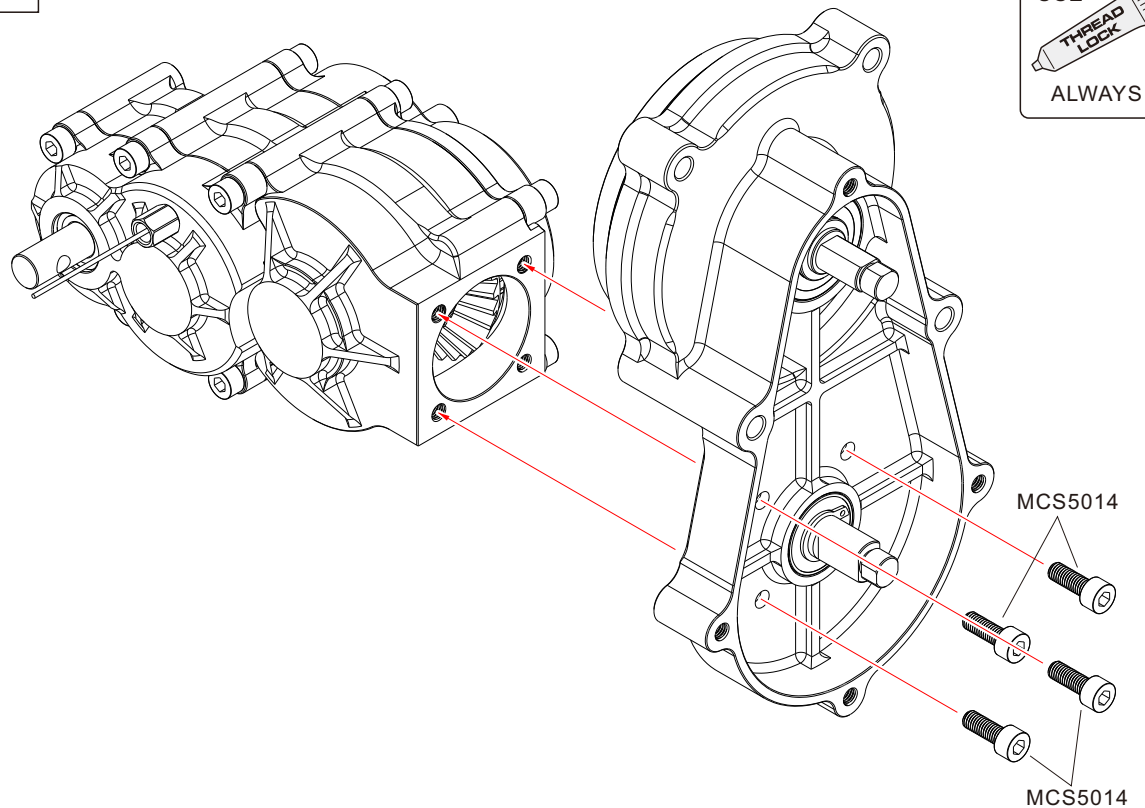

USE
**THREAD
LOCK**
ALWAYS



MES70
E-clip 7mm



×2

31

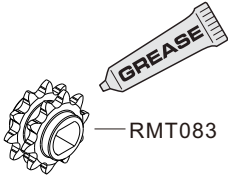

RMT083

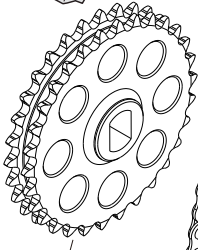

RMT084

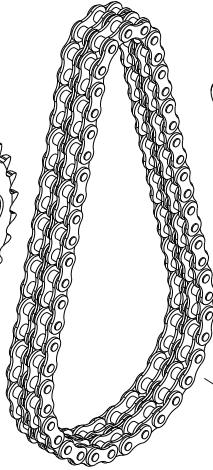

RMT093

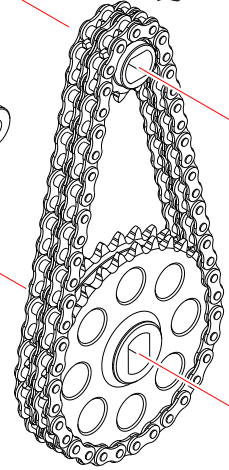
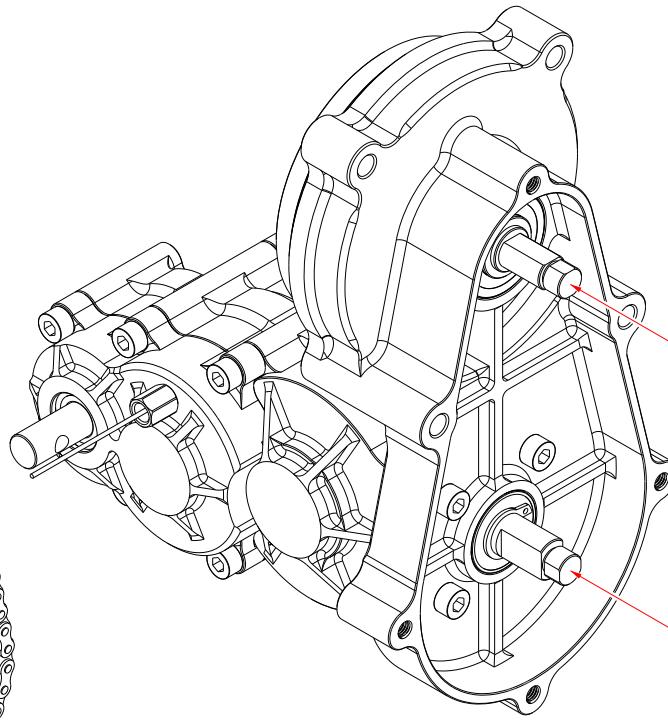

MES70

MES70

32 Engine Assembly

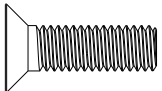

MFS6020
M6×20mm

×2

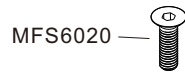

MFS6020



MFS6020

RMT014

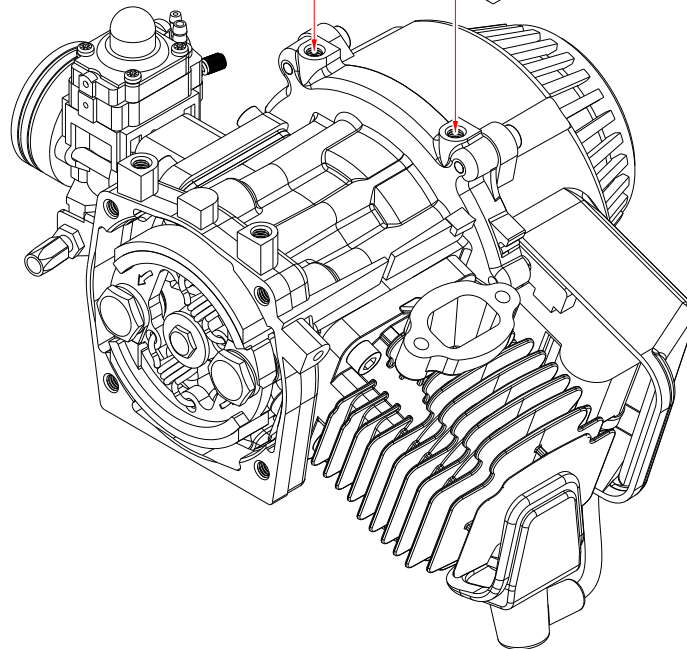

USE



ALWAYS

33



MCS6035
M6x35mm x2

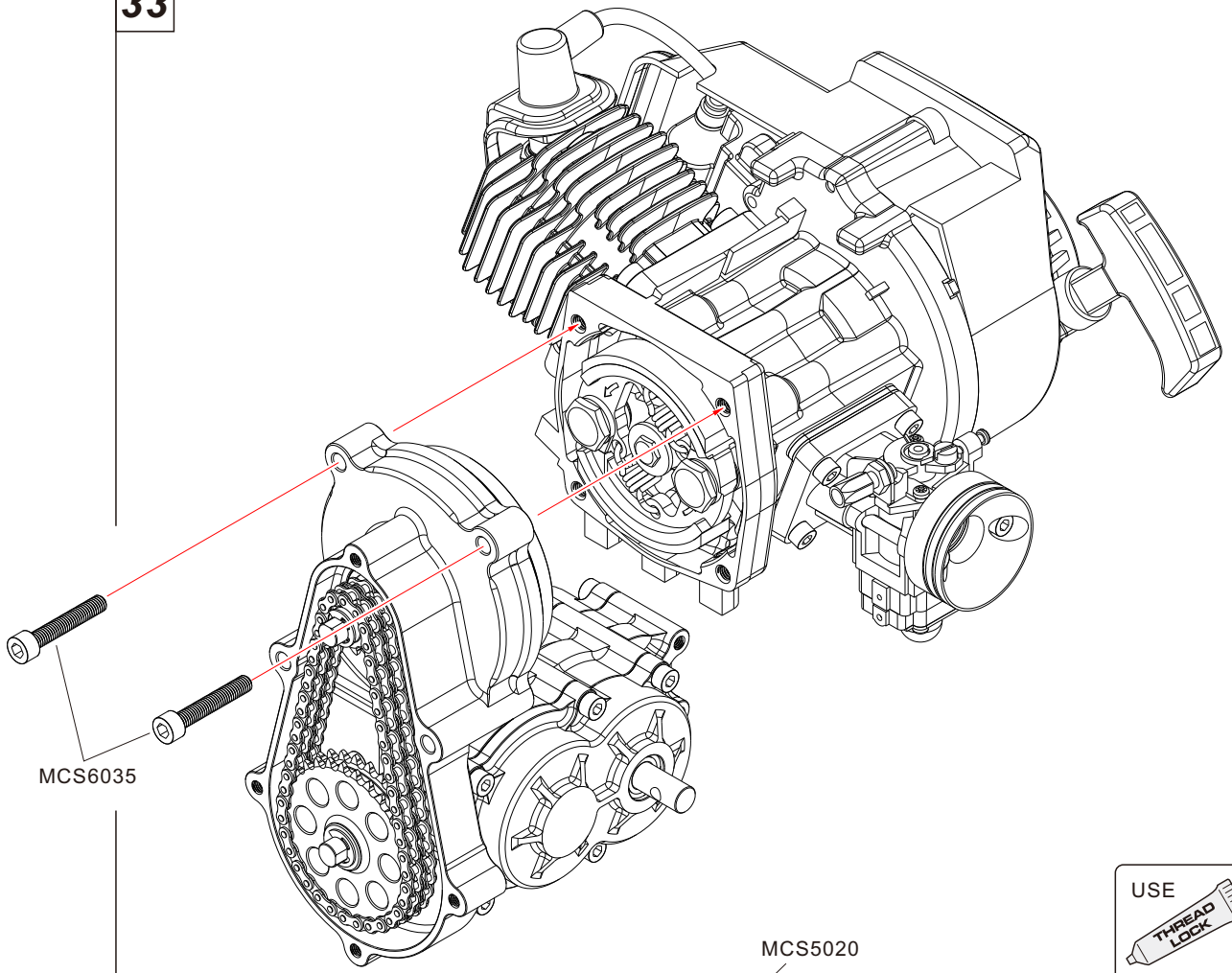

MCS6035

USE
THREAD
LOCK
ALWAYS

34

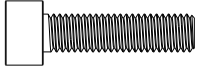

MCS5020
M5x20mm x3

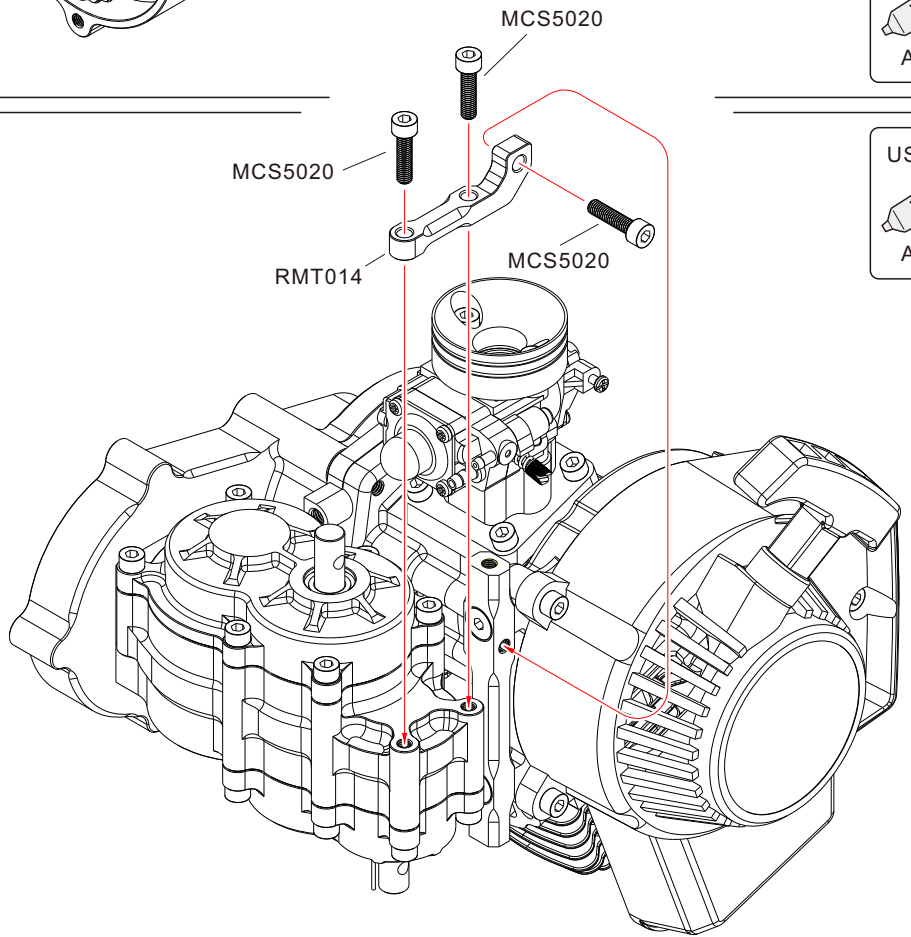

MCS5020





MCS5020

RMT014

MCS5020



USE
THREAD
LOCK
ALWAYS

37 Chassis Assembly

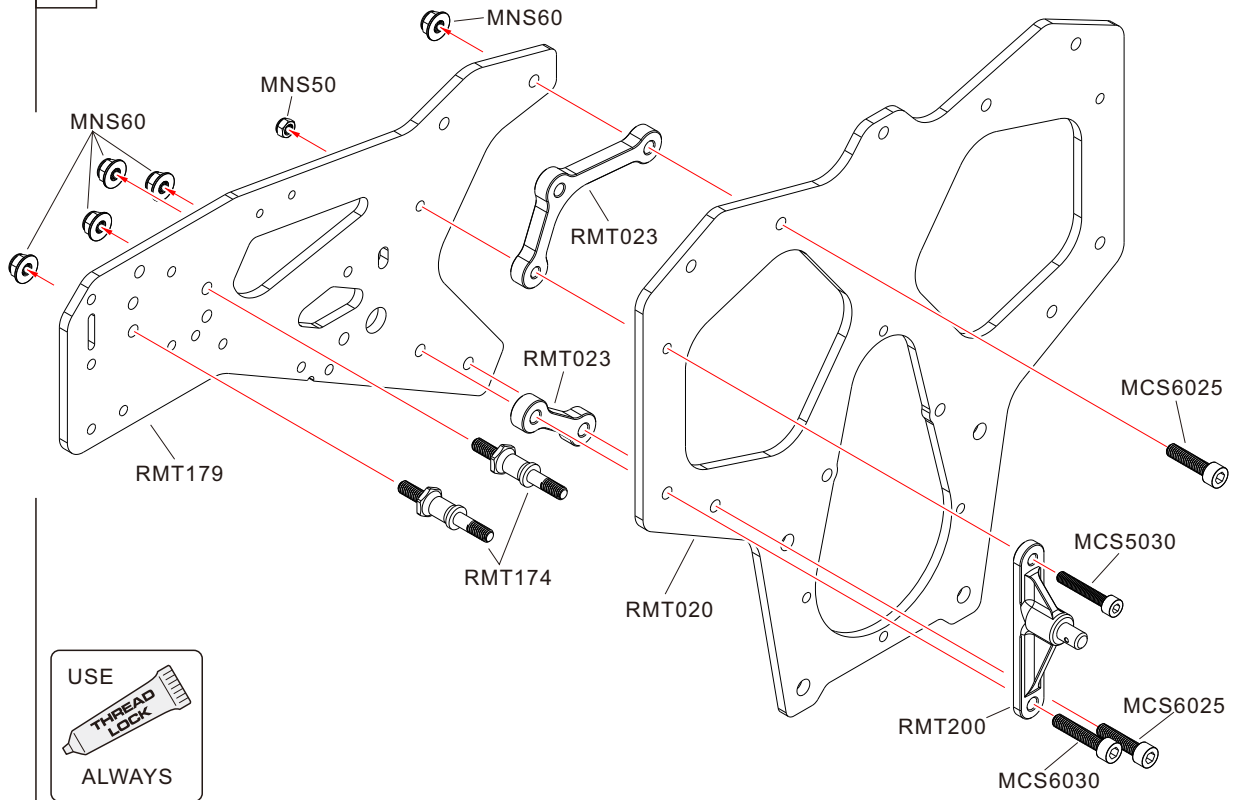
-  MNS50
M5 Nylon Lock Nut **x1**
-  MNS60
M6 Nylon Lock Nut **x5**
-  MCS5030
M5x30mm **x1**
-  MCS6025
M6x25mm **x2**
-  MCS6030
M6x30mm **x1**

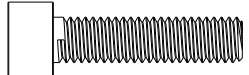

38

-  MNS60
M6 Nylon Lock Nut **x5**
-  MCS6025
M6x25mm **x2**
-  MCS6030
M6x30mm **x1**

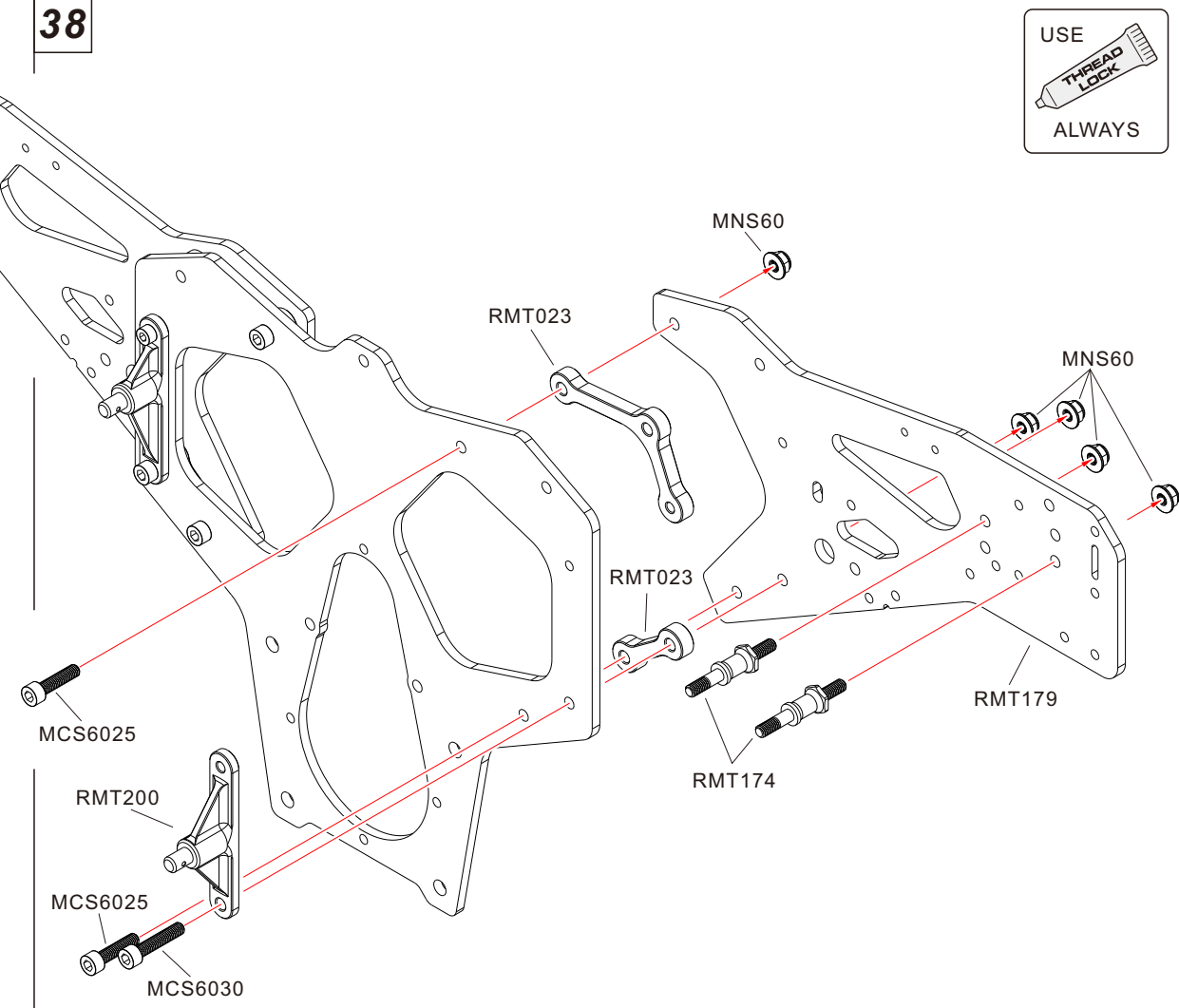

39



MNS60
M6 Nylon Lock Nut

x5



MCS6025
M6x25mm

x2



MCS6030
M6x30mm

x1

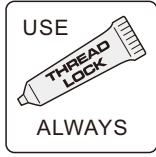
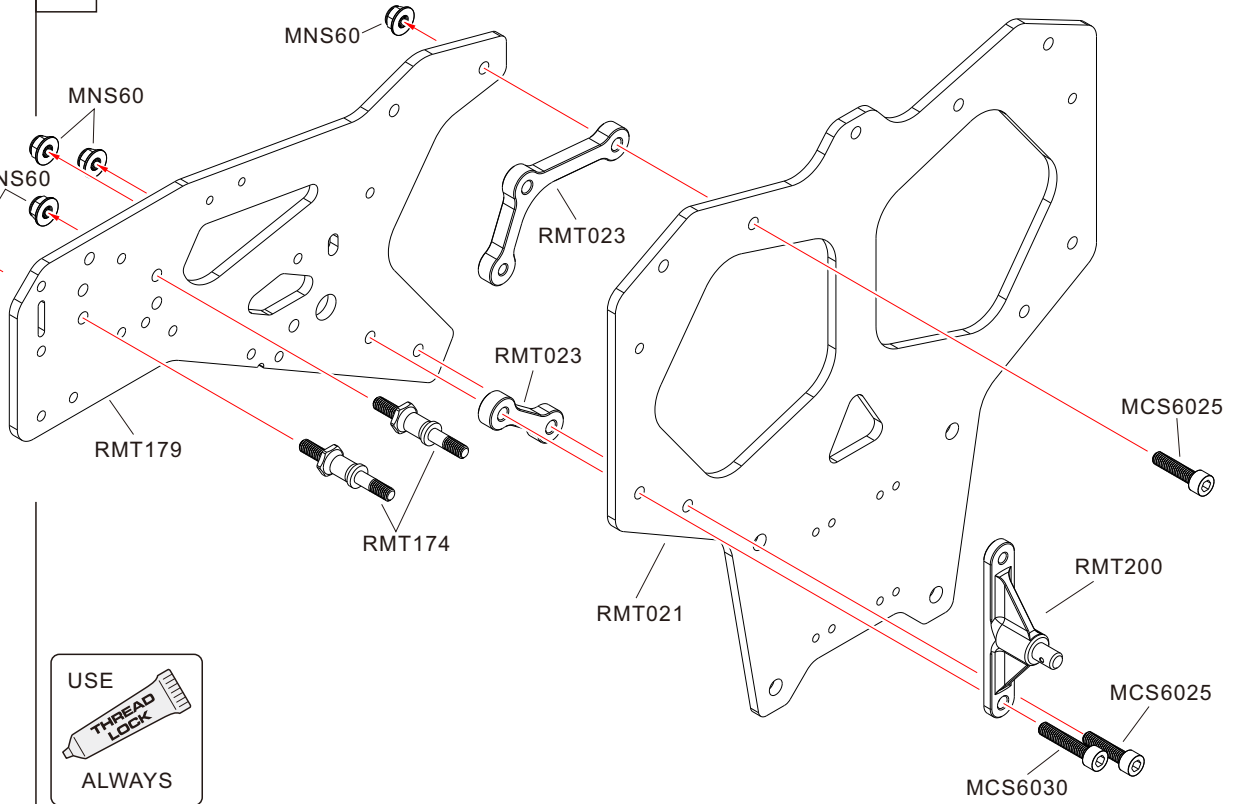

40



MCS5030
M5x30mm

x1



MCS6025
M6x25mm

x2



MCS6030
M6x30mm

x1

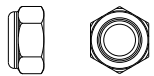

MNS50
M5 Nylon Lock Nut

x1



MNS60
M6 Nylon Lock Nut

x5

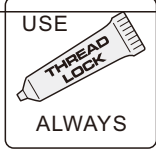
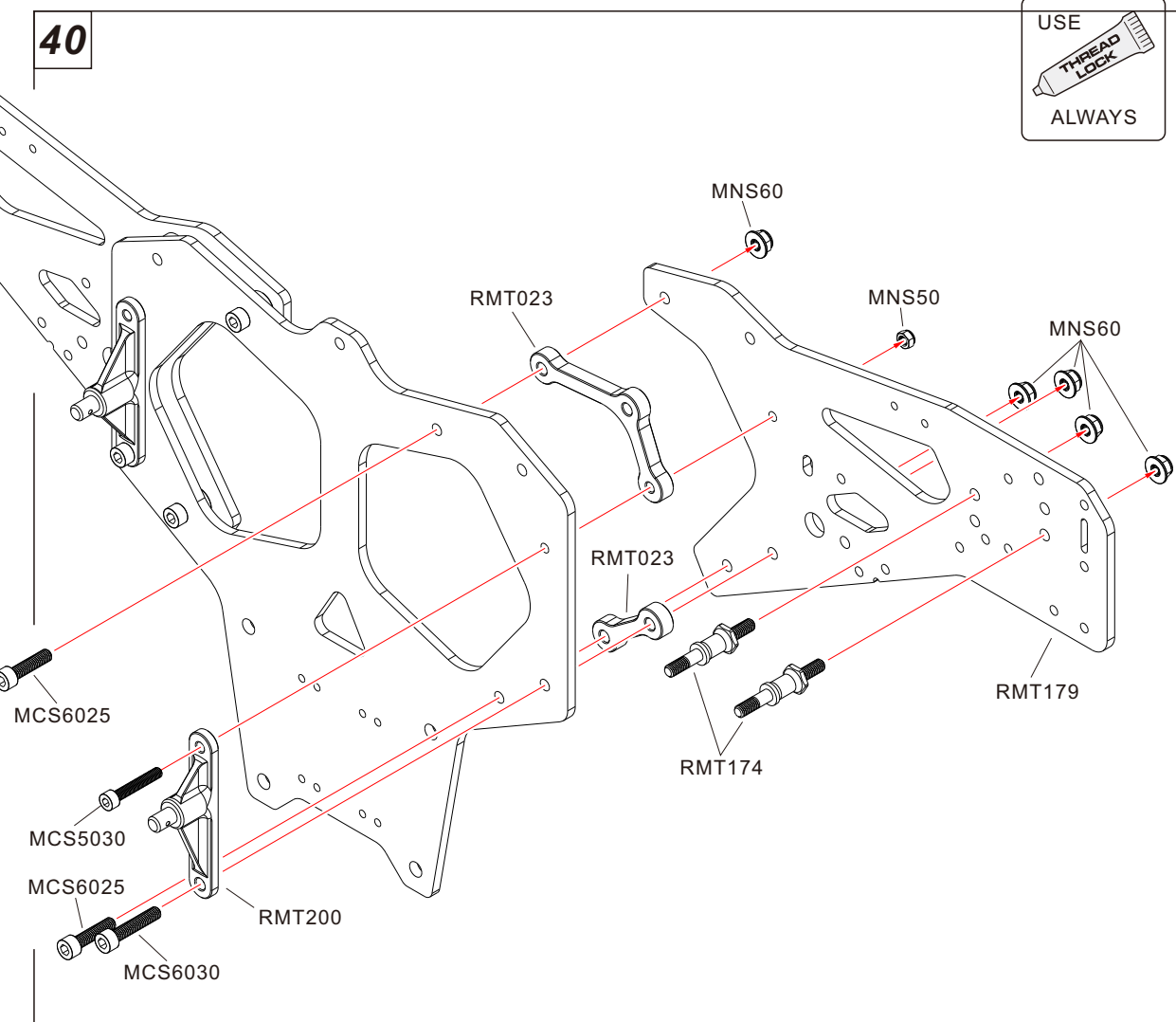

MCS3012
M3×12mm ×8

MCS4012
M4×12mm ×4

MCS4016

MCS4016

MCS4016
M4×16mm ×8

MCS6010
M6×10mm ×1

MCS5016
M5×16mm ×2

MNS60
M6 Nylon Lock Nut ×1

MWS061612
Washer 6×16×1.2mm ×1

MPS60
Spring Washer M6 ×1

MCS6065
M6×65mm ×2

41

MFS3010
M3×10mm ×2

MNS40
M4 Nylon Lock Nut ×2

MWS030810
Washer 3×8×1mm ×8

RMT030 RMT062
MNS40 ×2

USE
THREAD
LOCK
ALWAYS

RMT032 Reverse Servo Assembly

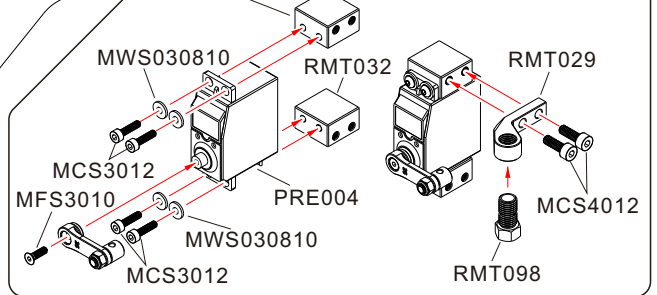

RMT032 Throttle Servo Assembly

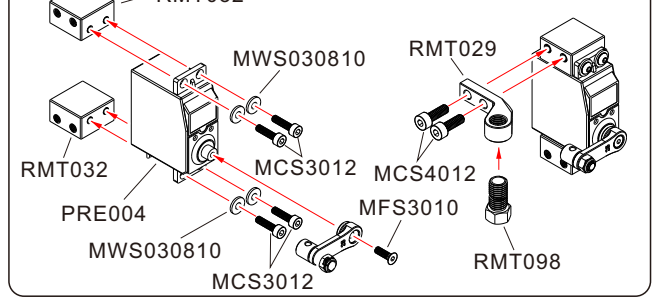

Throttle Servo

Reverse Servo

42

MNS60 MPS60
MWS061612

USE
THREAD
LOCK
ALWAYS

RMT148

MCS6010

MCS6065

MCS6065

MCS5016

MCS5016

43



MCS5020
M5x20mm ×2

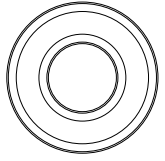

BBS092006
Bearing 9x20x6mm ×2

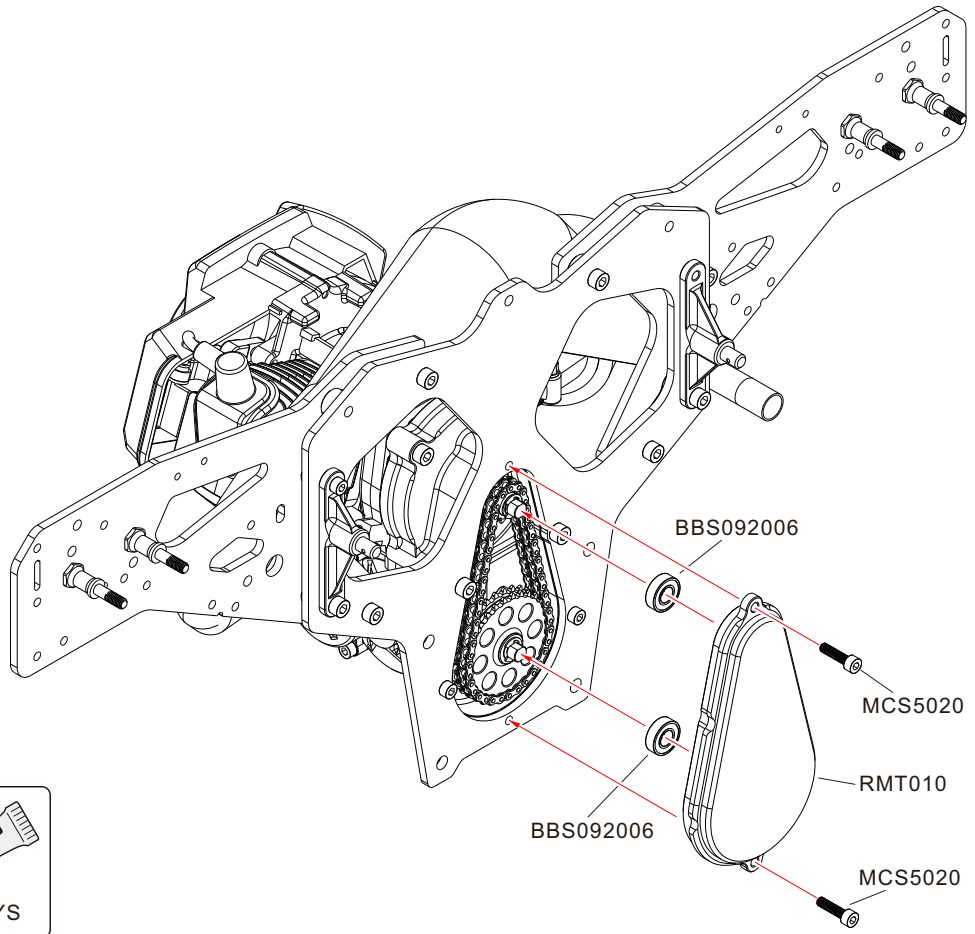
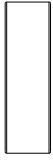

USE

ALWAYS

44

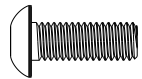

MBS5014
M5x14mm ×2

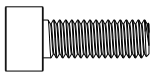

MCS5014
M5x14mm ×1

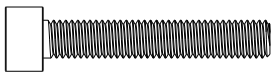

MCS5030
M5x30mm ×1

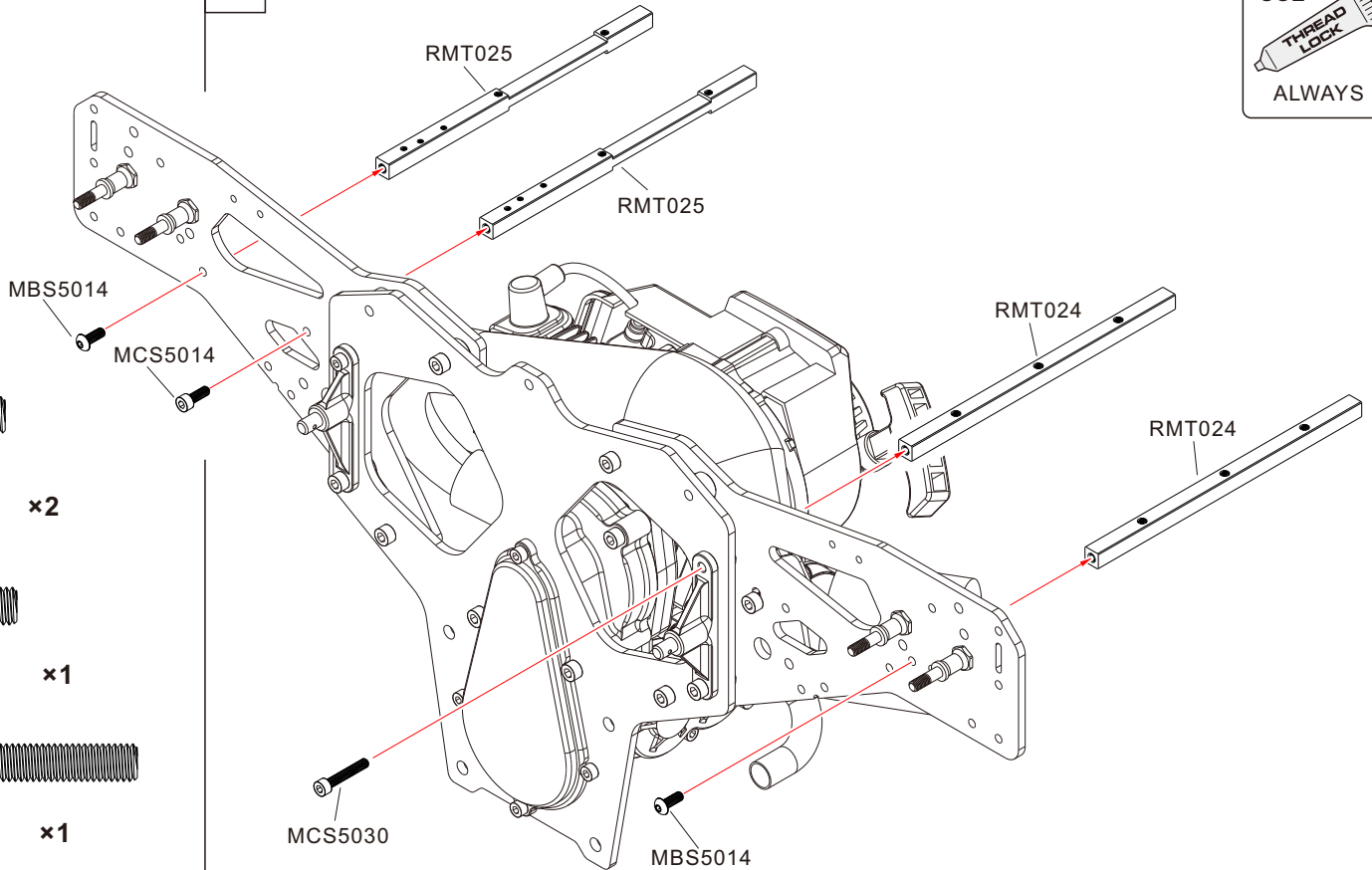

USE

ALWAYS

45

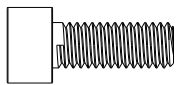

MCS6016
M6×16mm ×3

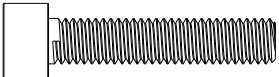

MCS6030
M6×30mm ×2

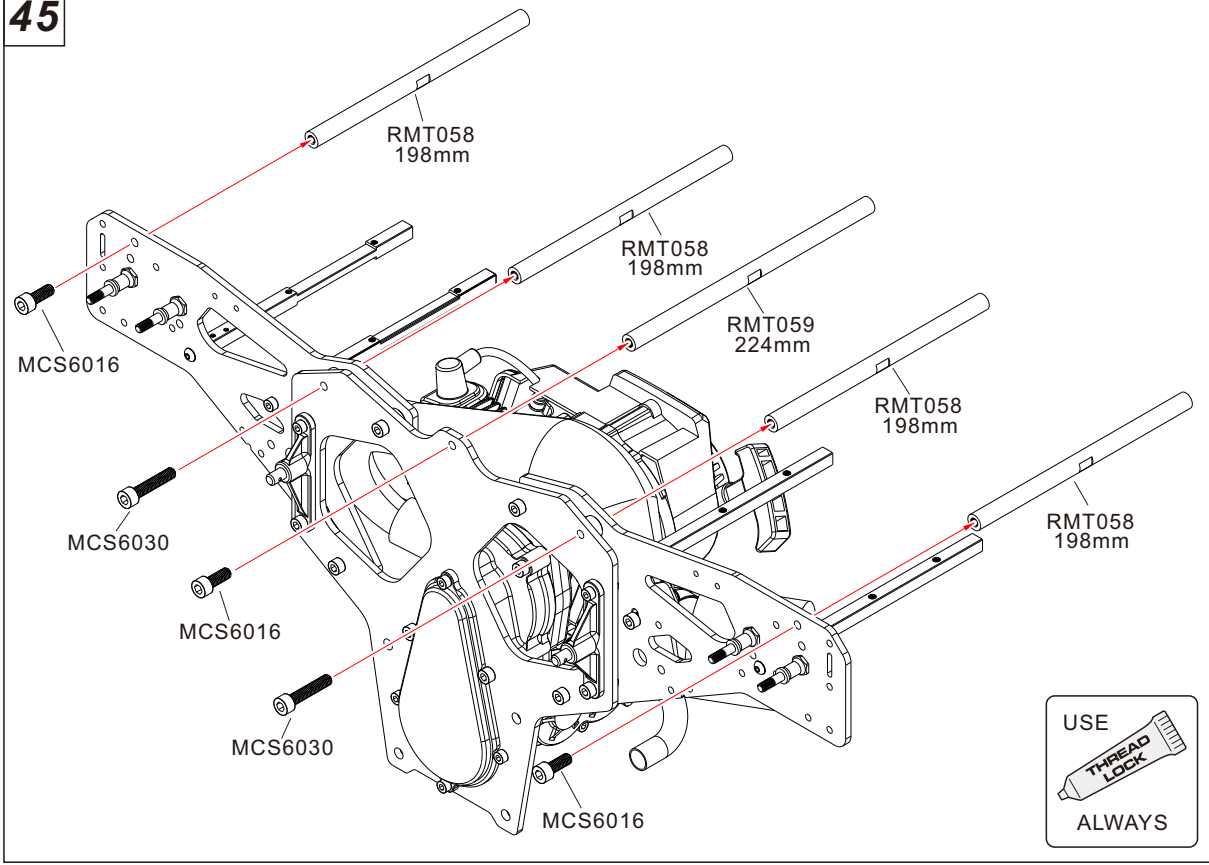

46

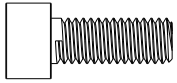

MCS6016
M6×16mm ×3



MCS6030
M6×30mm ×2

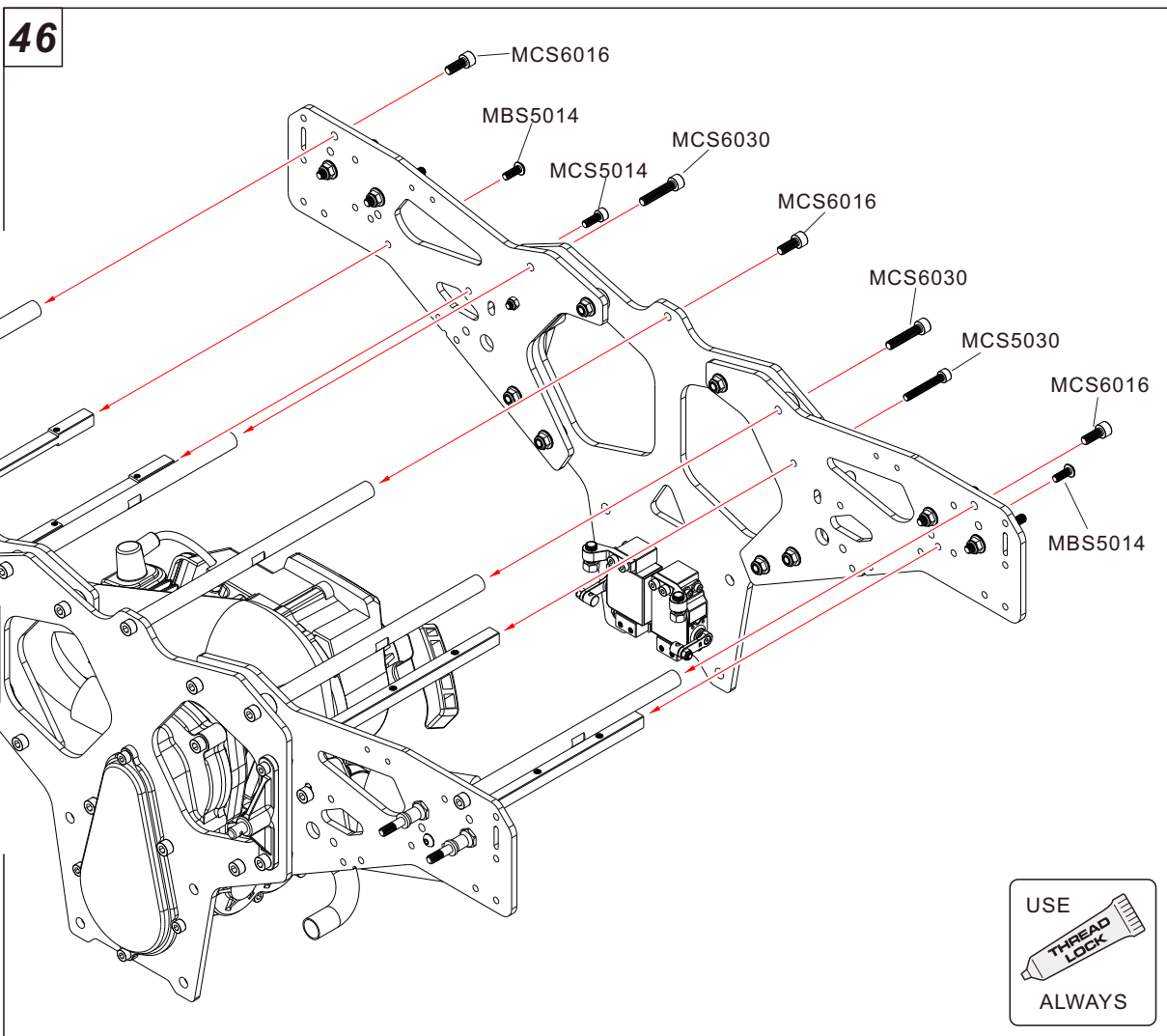

47 Fuel Tank Assembly

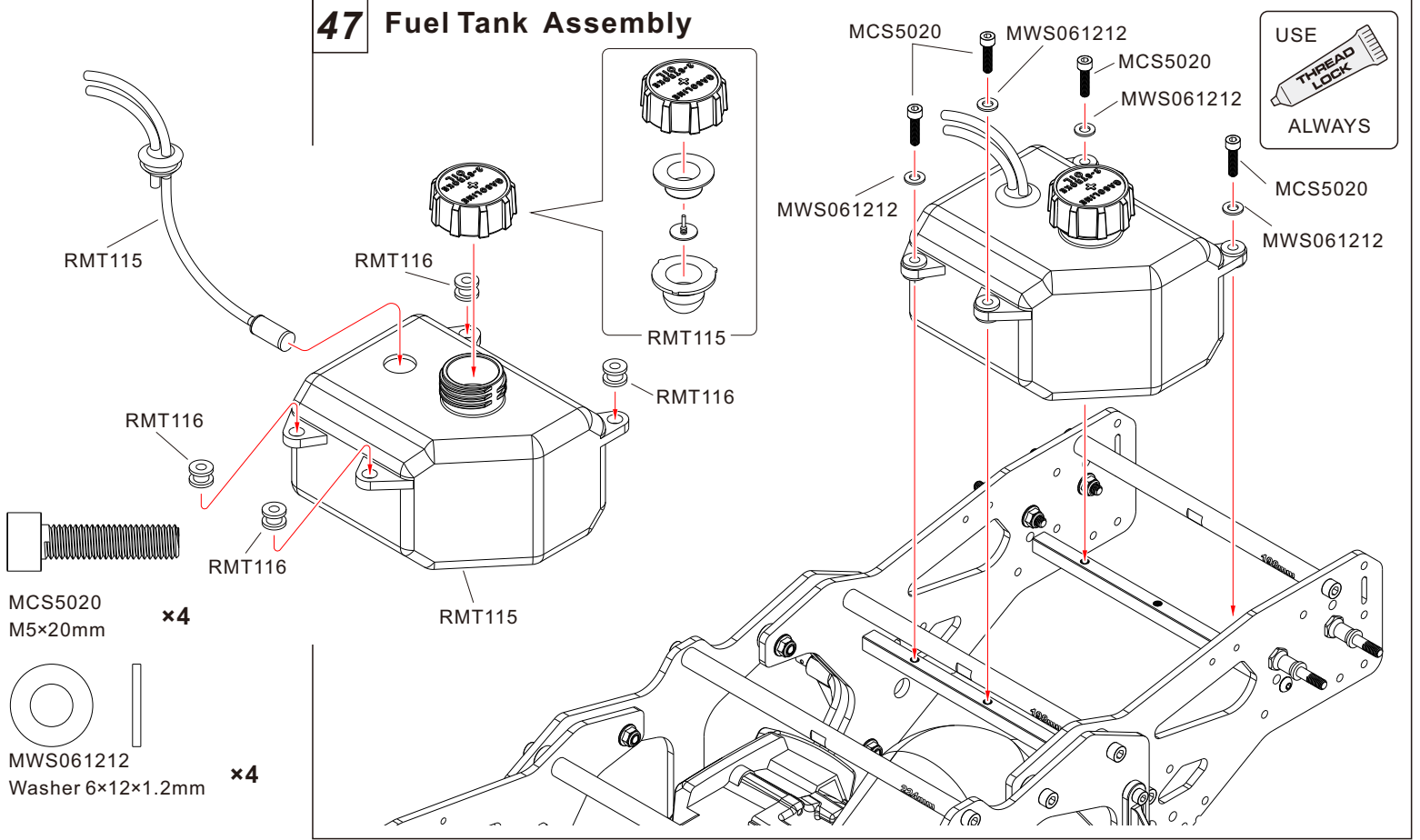

48

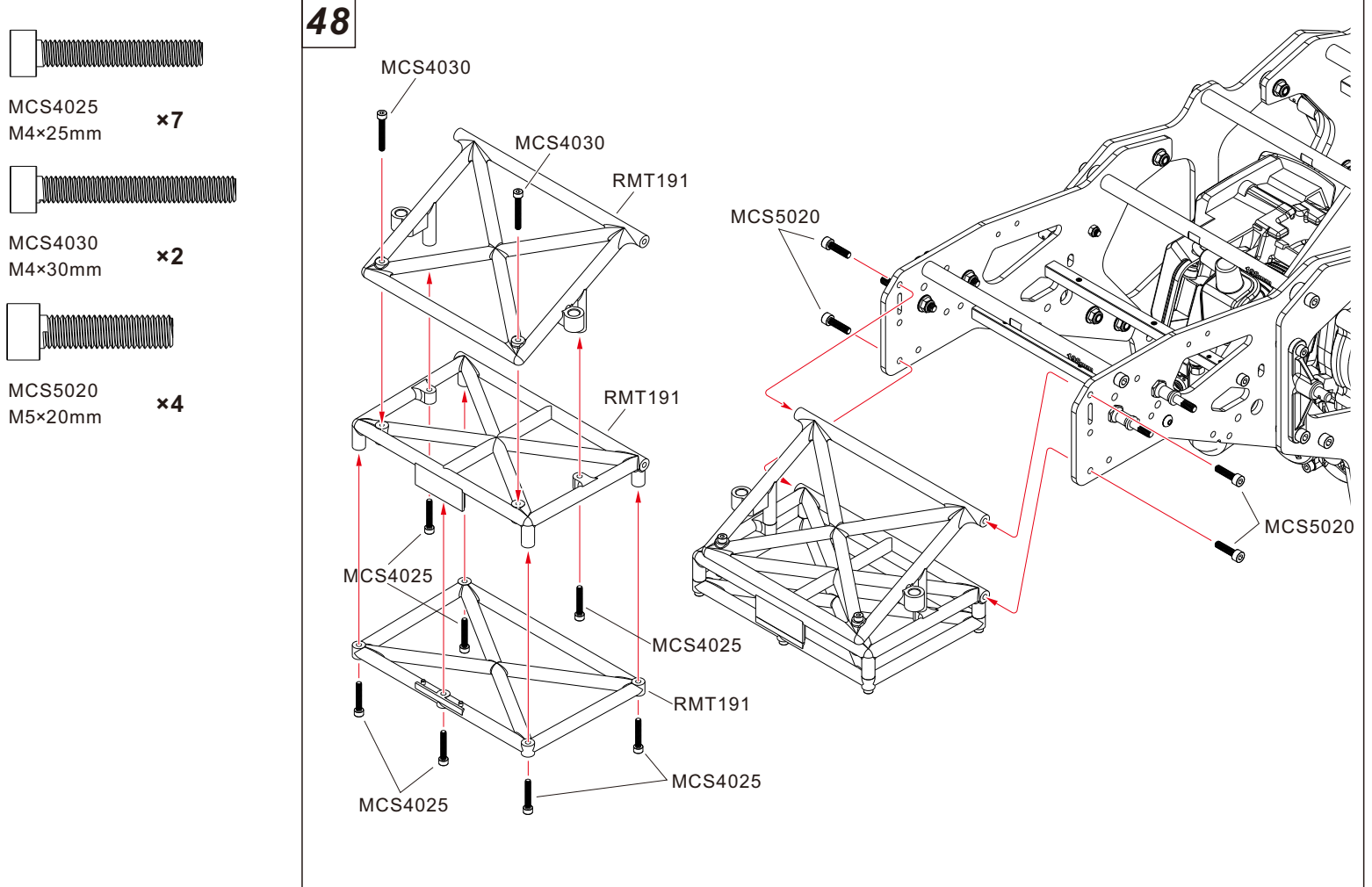

49 Receiver Assembly



MCS4025
M4x25mm **x8**



MBS3006
M3x6mm **x6**



MNNS60
M6 Nut **x1**



MBS2506
M2.5x6mm **x2**



MCS3028
M3x28mm **x4**



MFS3005
M3x5mm **x4**



MFS4010
M4x10mm **x4**

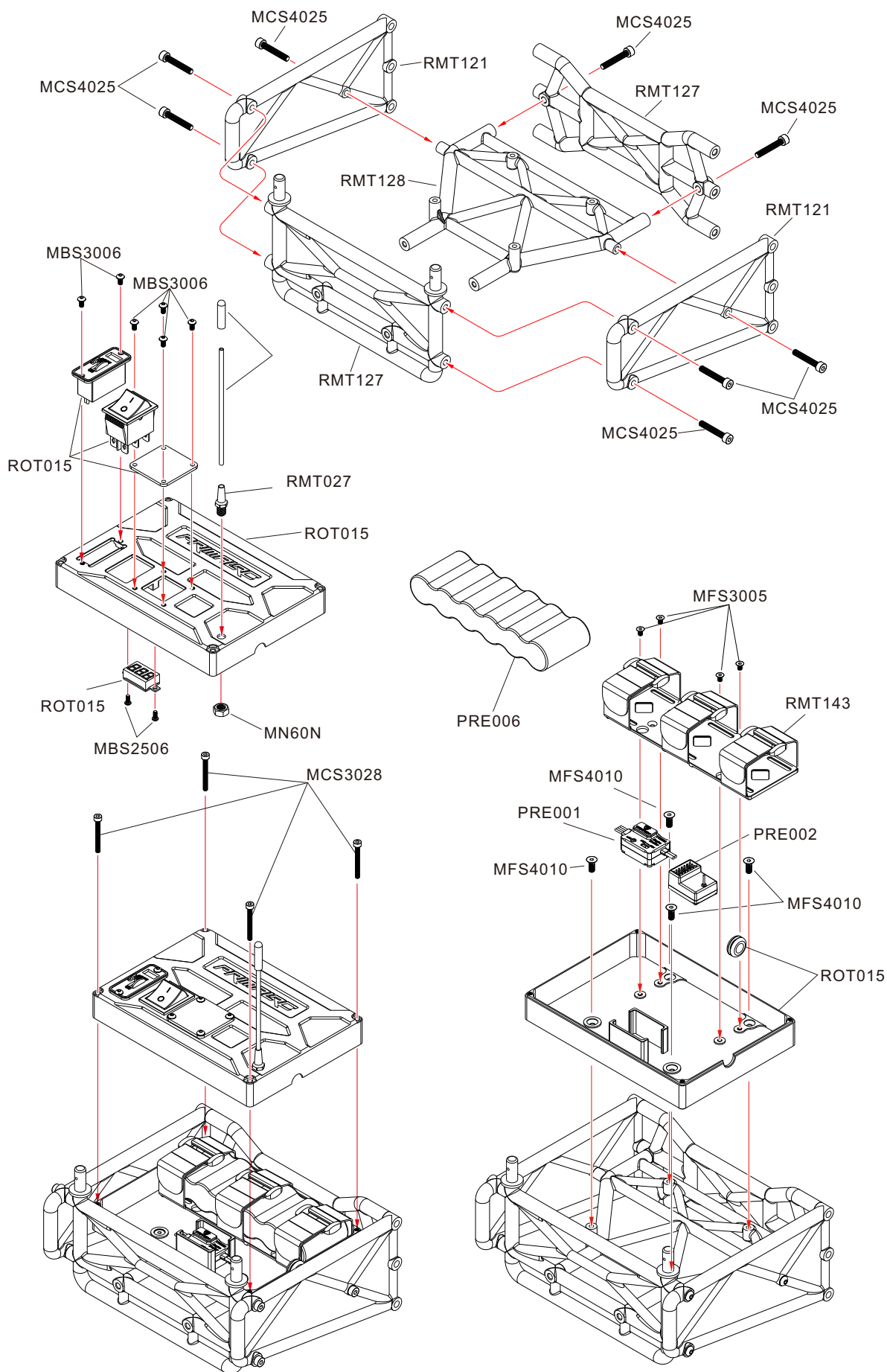

50



MCS5025
M5×25mm ×4

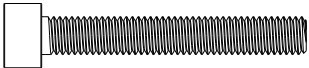

MCS5035
M5×35mm ×2

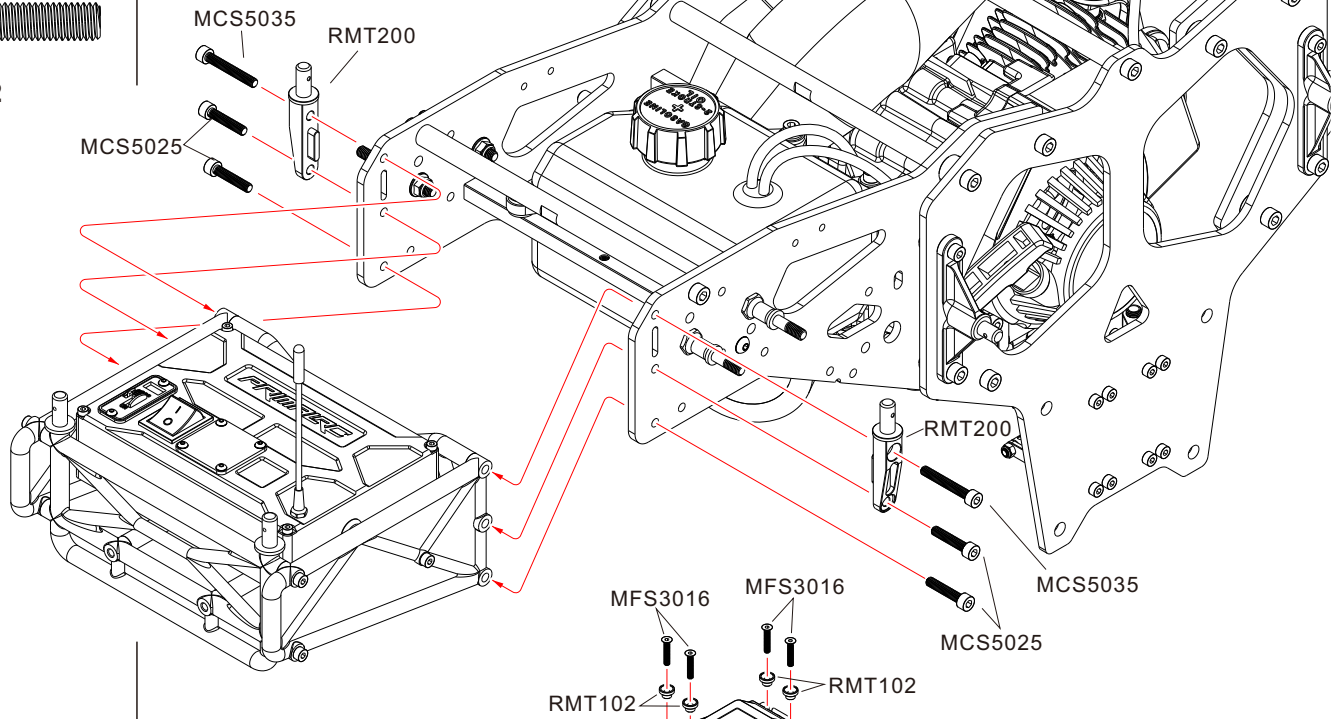

51



MFS3016
M3×16mm ×4



MWS040805
Washer 4×8×0.5mm ×1



MCS2508
M2.5×8mm ×1

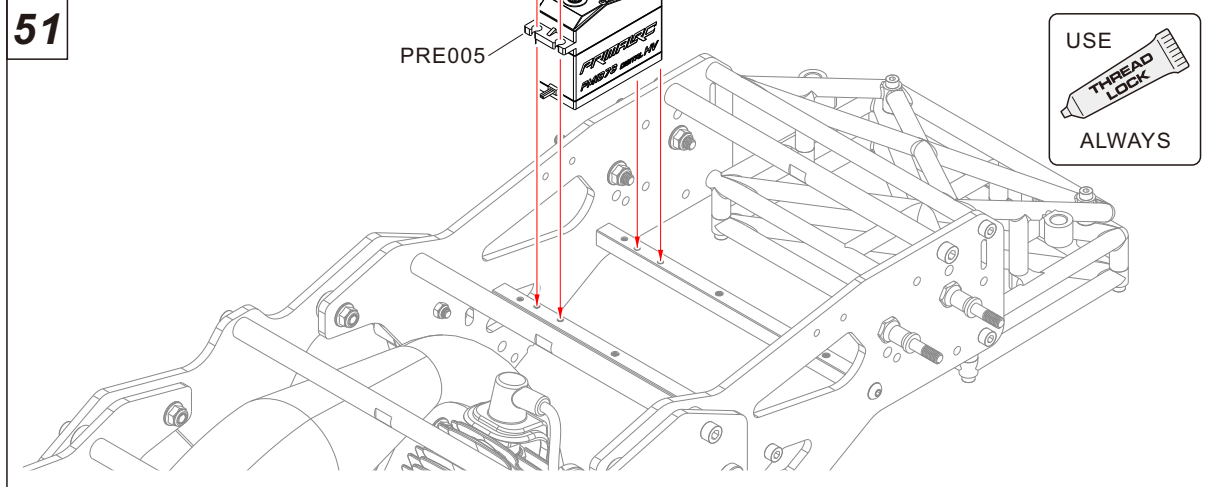

USE
THREAD
LOCK
ALWAYS

52



MCS3008
M3×8mm ×1



MCS4012
M4×12mm ×1

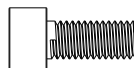

MCS5012
M5×12mm ×2

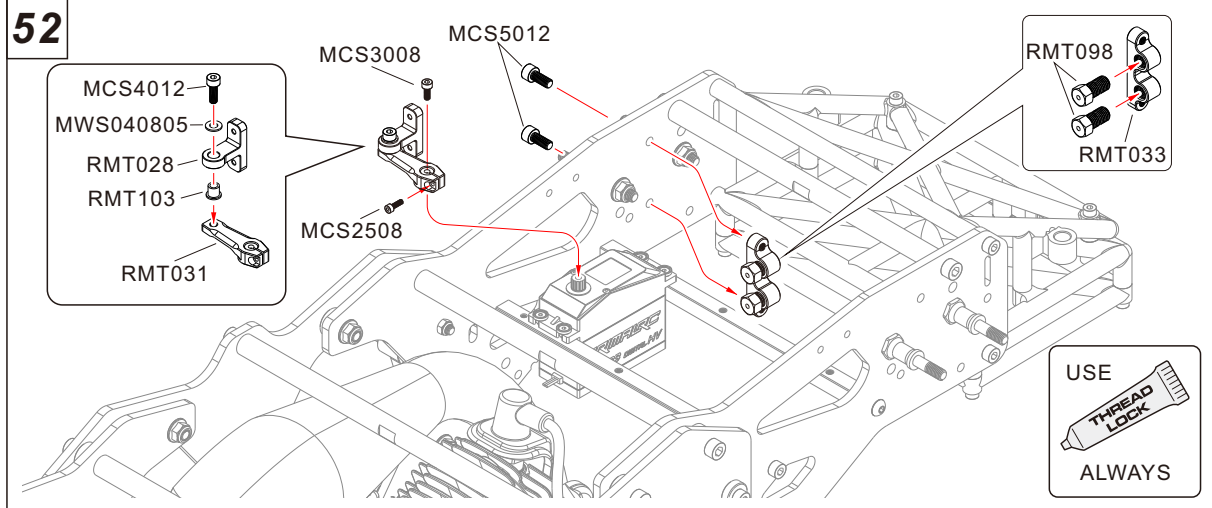

USE
THREAD
LOCK
ALWAYS

53

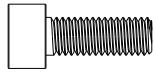

MCS5014
M5x14mm x4



MSS4004
M4x4mm x2

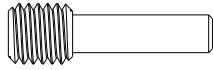

RMT055
M8x27mm x1

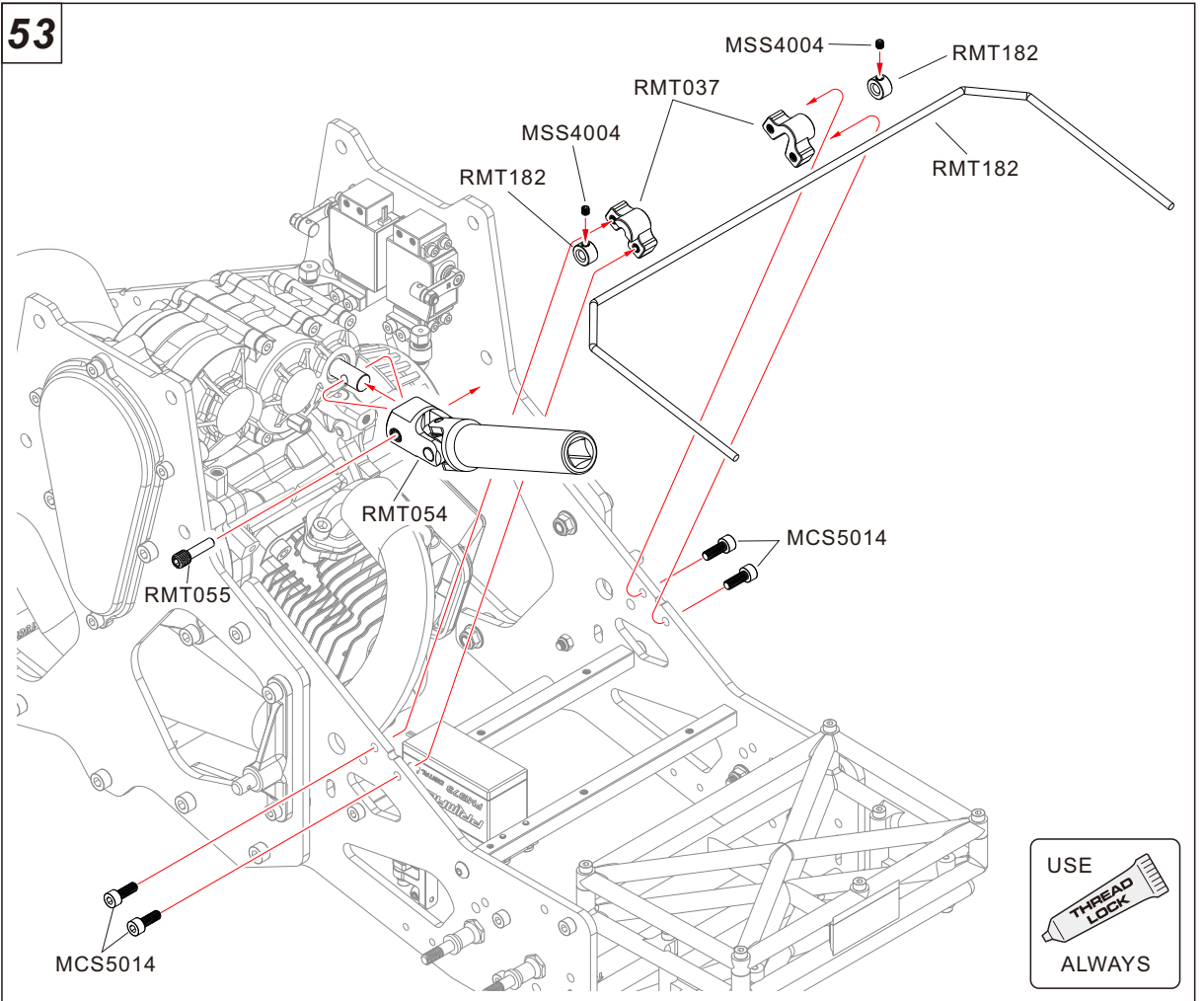

USE
THREAD
LOCK
ALWAYS

54

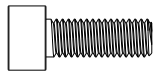

MCS5014
M5x14mm x4



MSS4004
M4x4mm x2

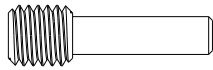

RMT055
M8x27mm x1

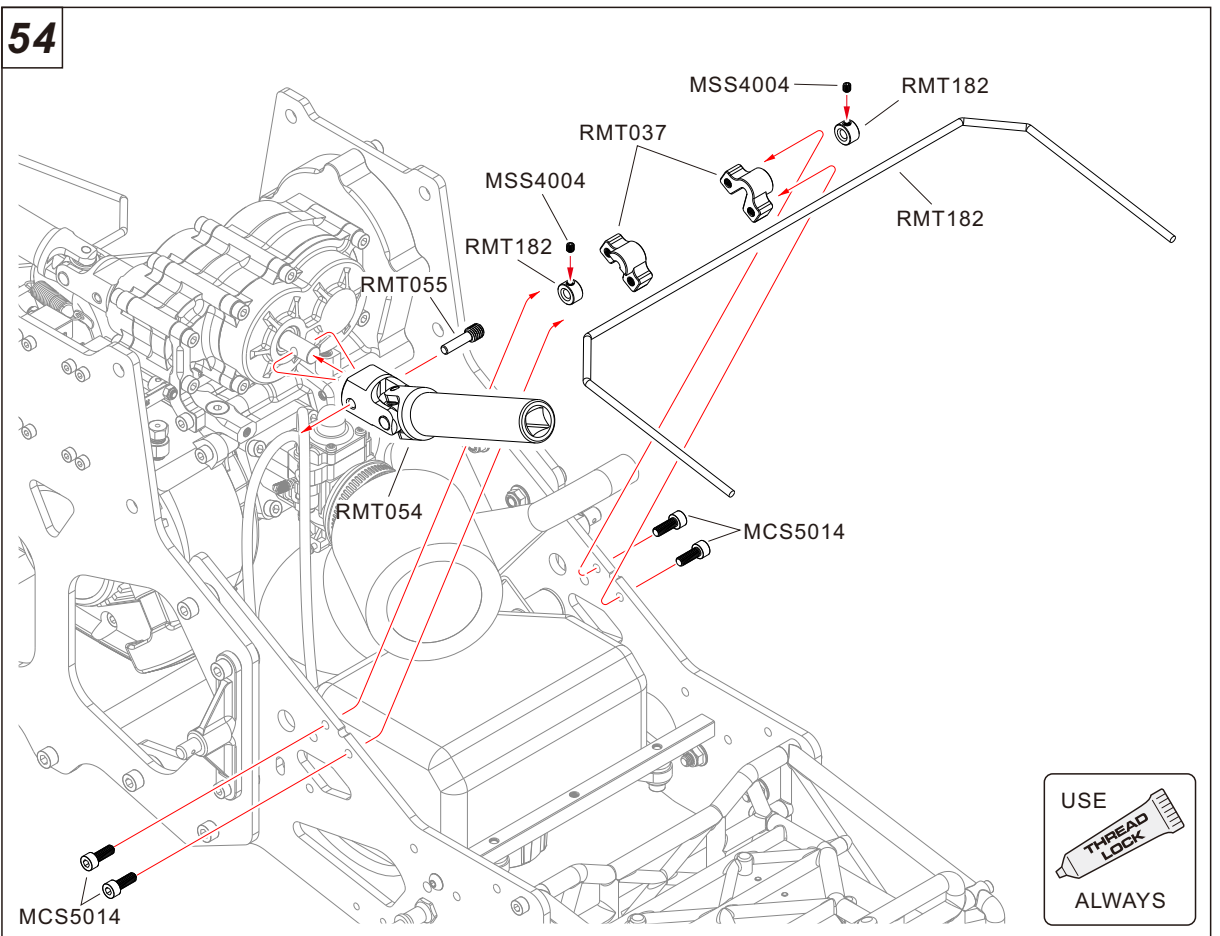

USE
THREAD
LOCK
ALWAYS

55 Linkage Assembly

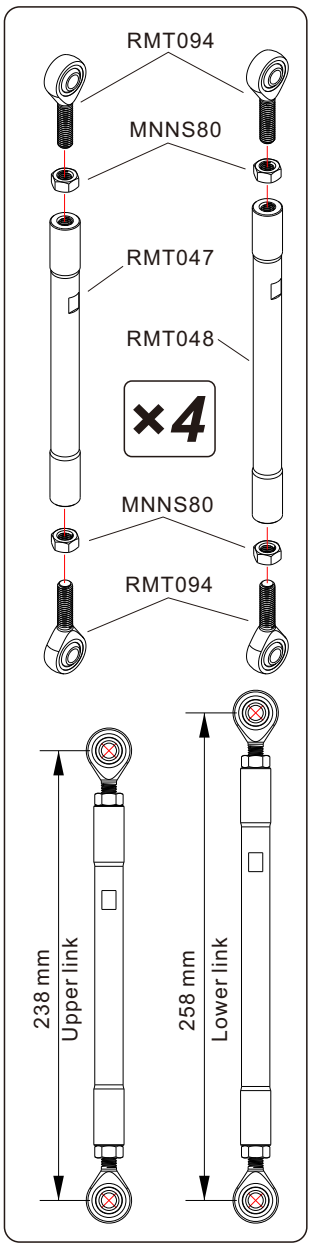
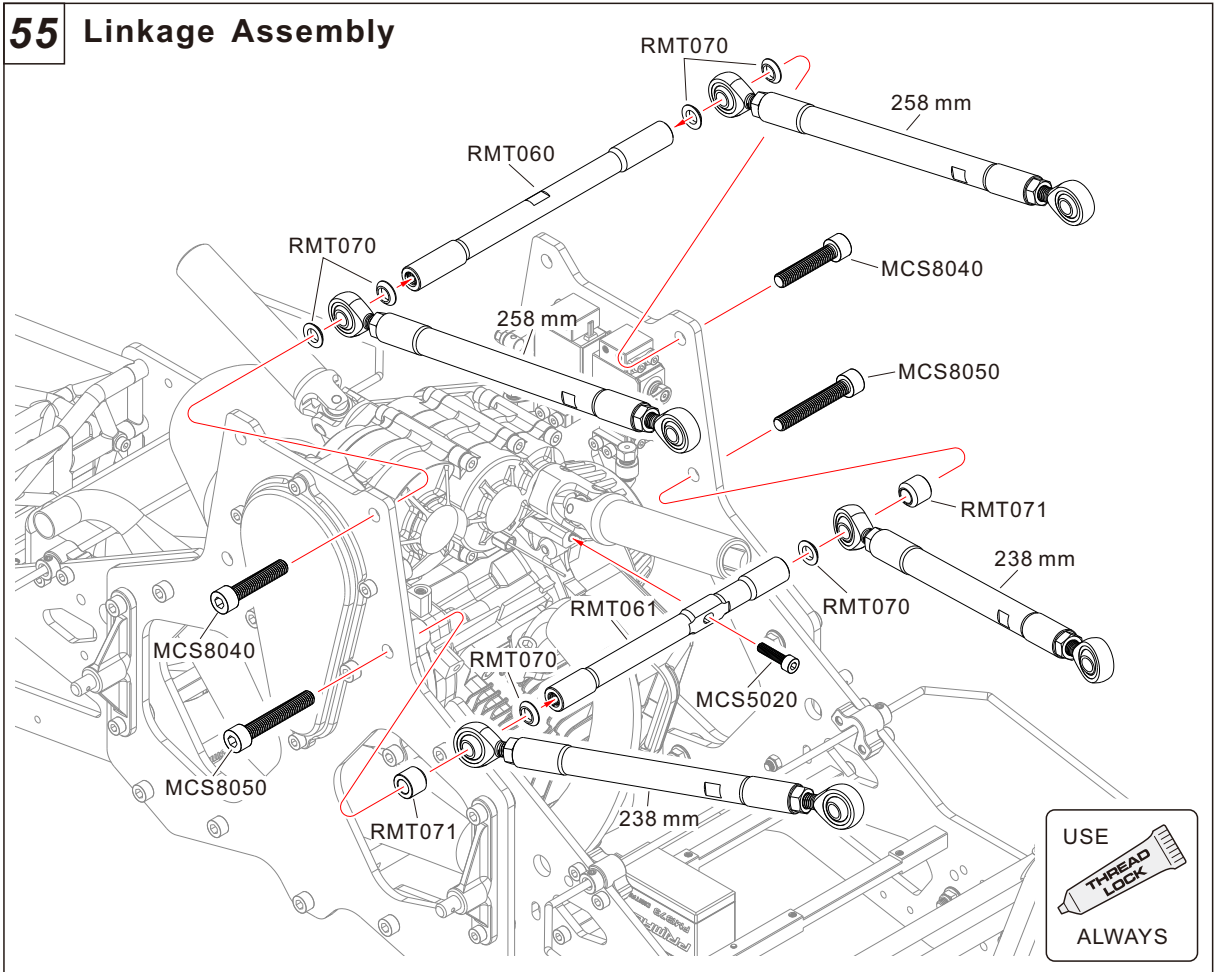
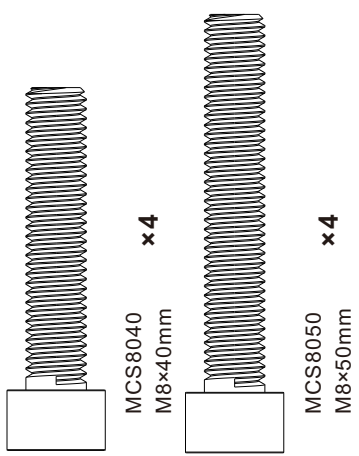
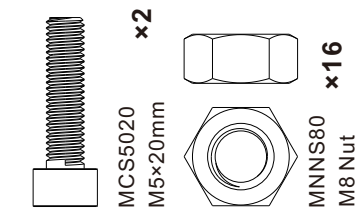

56

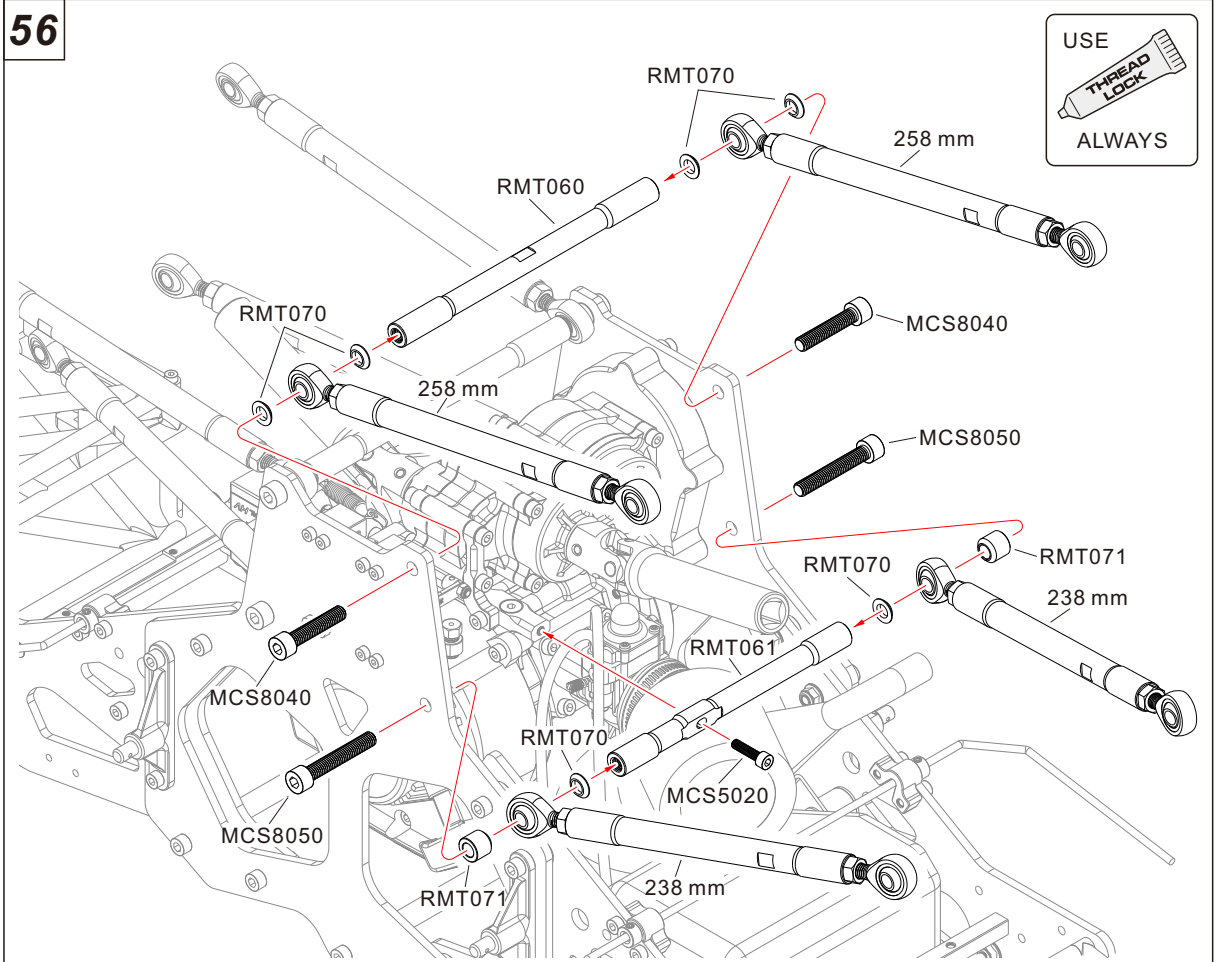

57 Axle Assembly

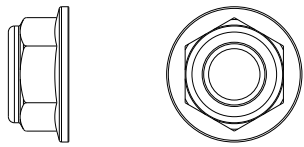

MNS80
M8 Nylon Lock Nut **x2**

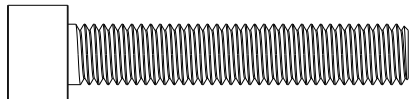

MCS8045
M8x45mm **x2**

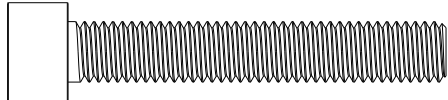

MCS8050
M8x50mm **x2**

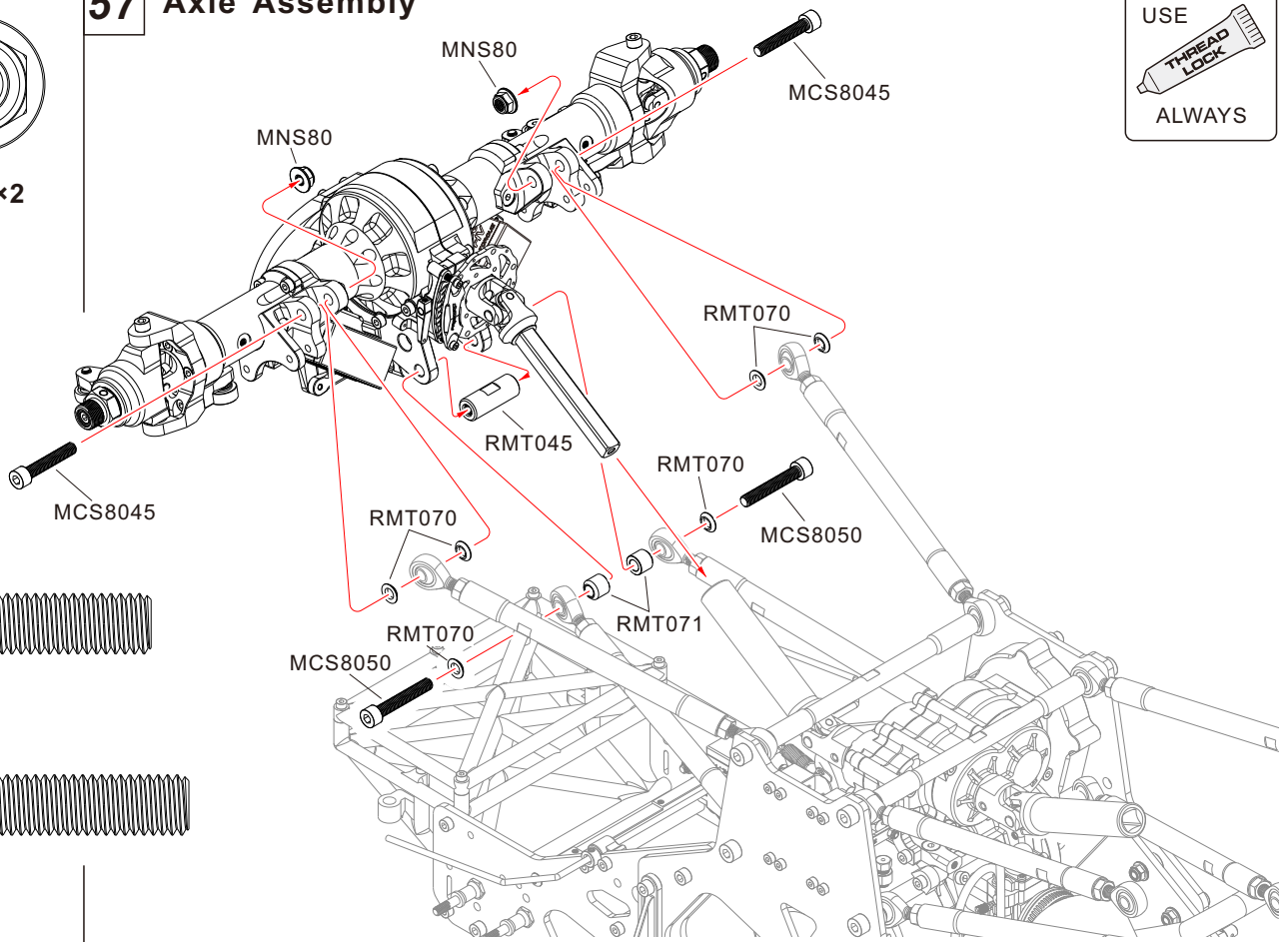

USE
**THREAD
LOCK**
ALWAYS

58

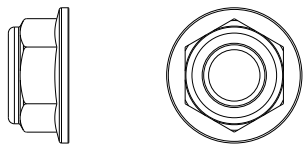

MNS80
M8 Nylon Lock Nut **x2**

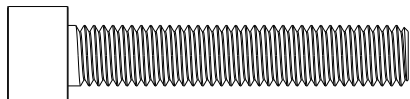

MCS8045
M8x45mm **x2**

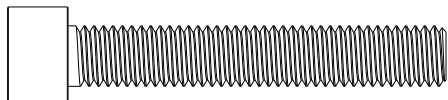

MCS8050
M8x50mm **x2**

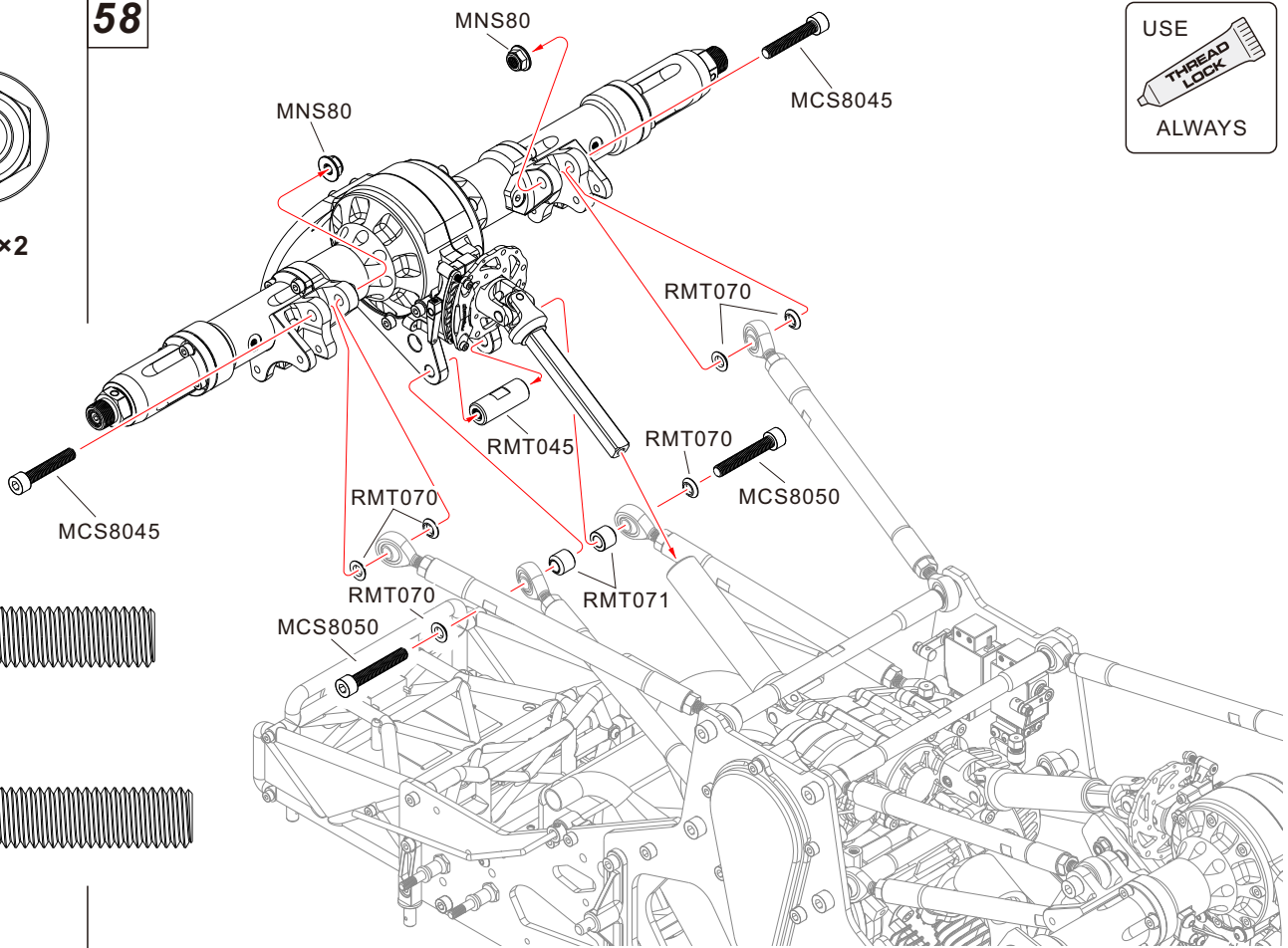

USE
**THREAD
LOCK**
ALWAYS

59 Shock Assembly

×4

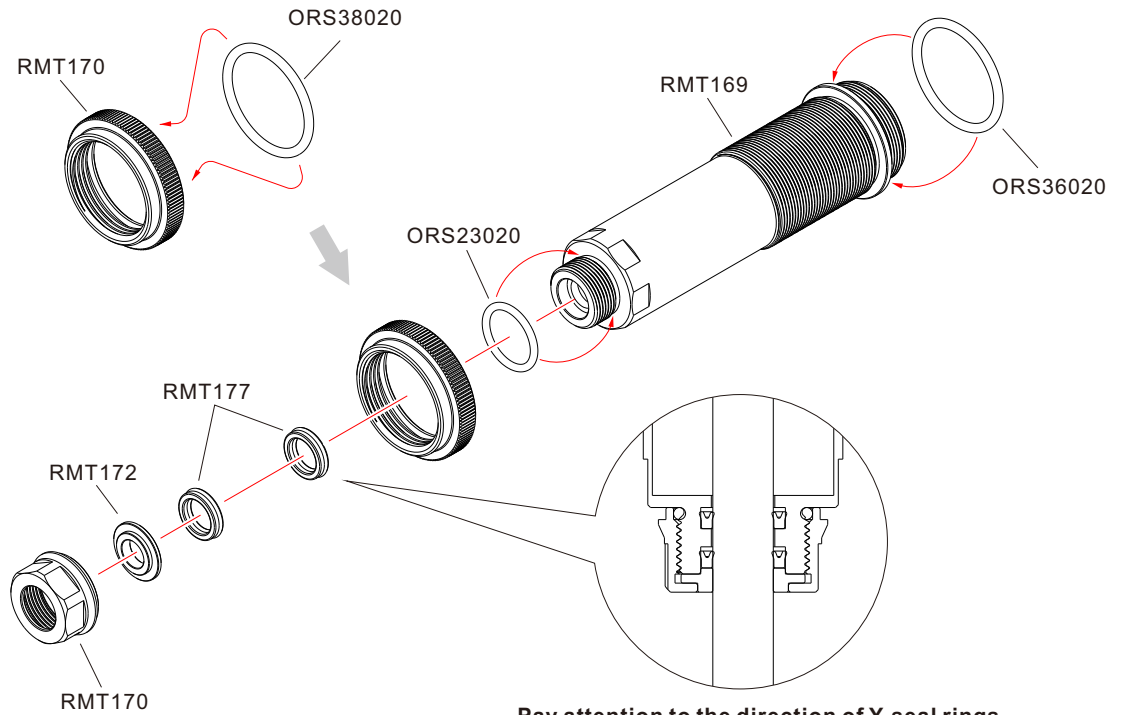
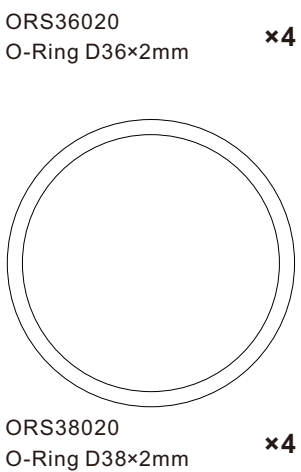
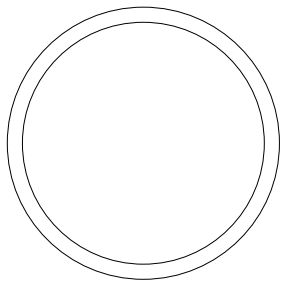
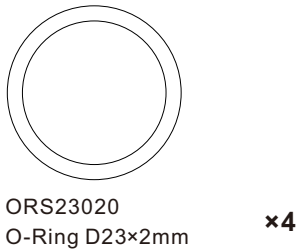
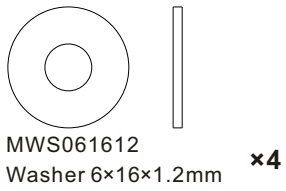
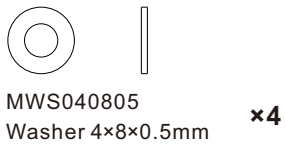

60

×4

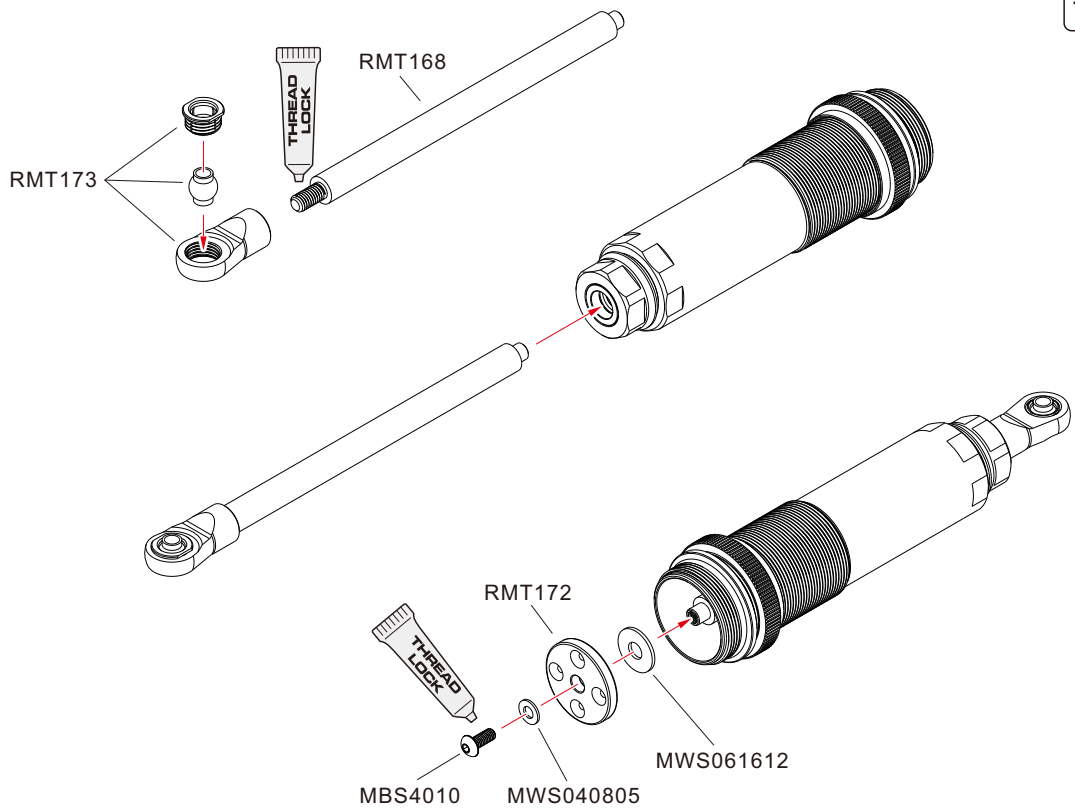

61

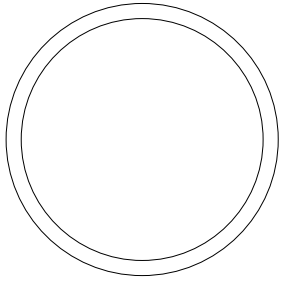

ORS36020
O-Ring D36x2mm

x4

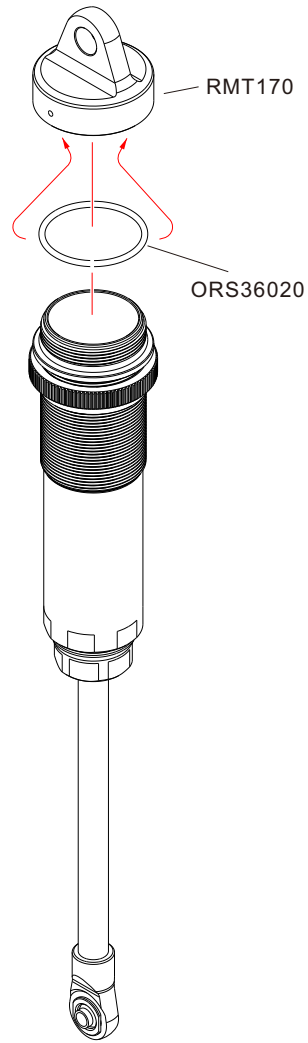
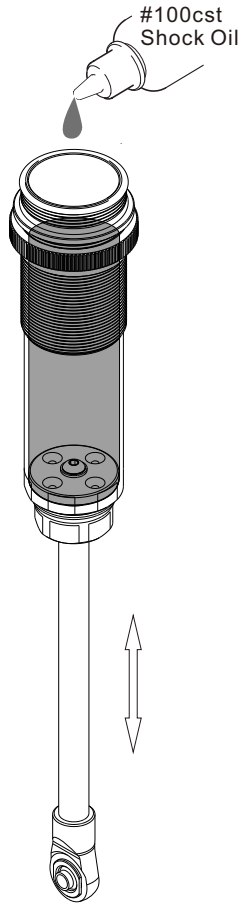

297.6mm

x4

62

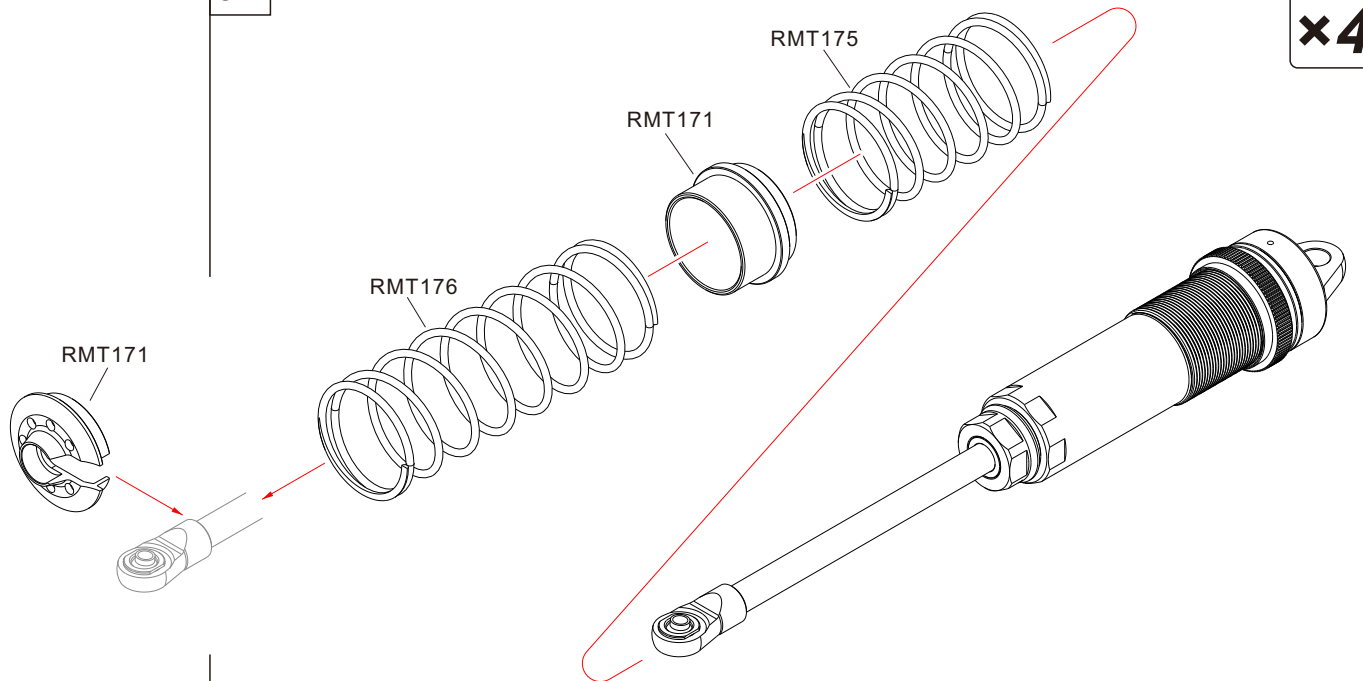

x4

63 Damper Shock Assembly

x4

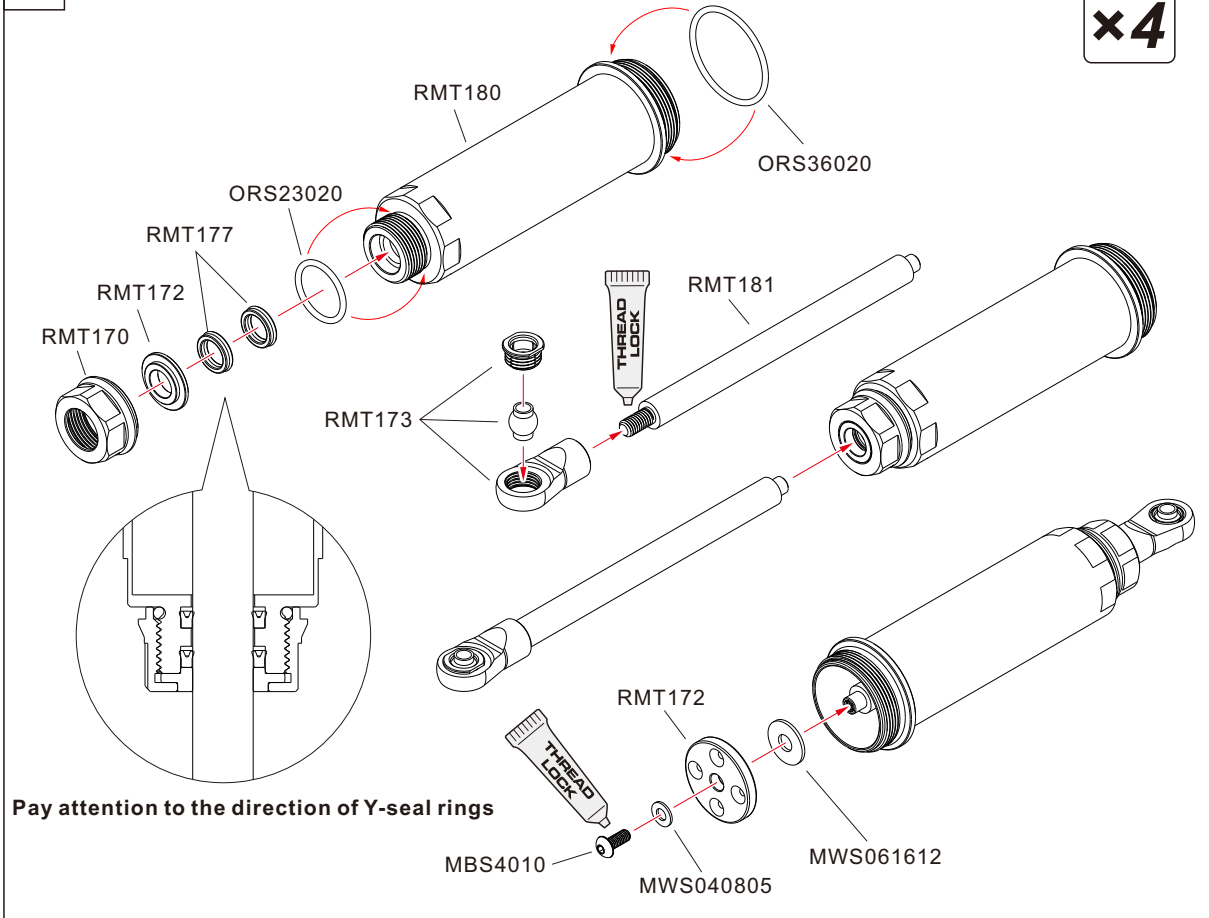
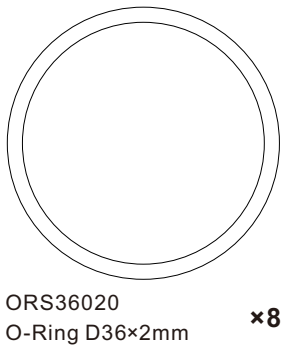
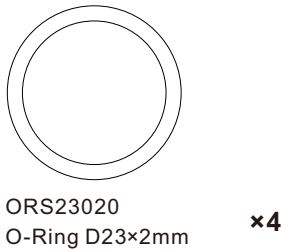
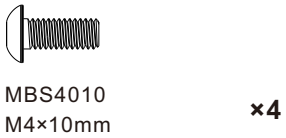
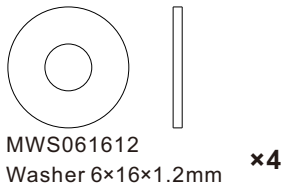
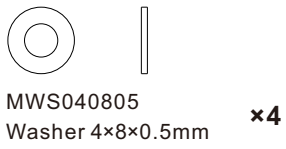

64

x4

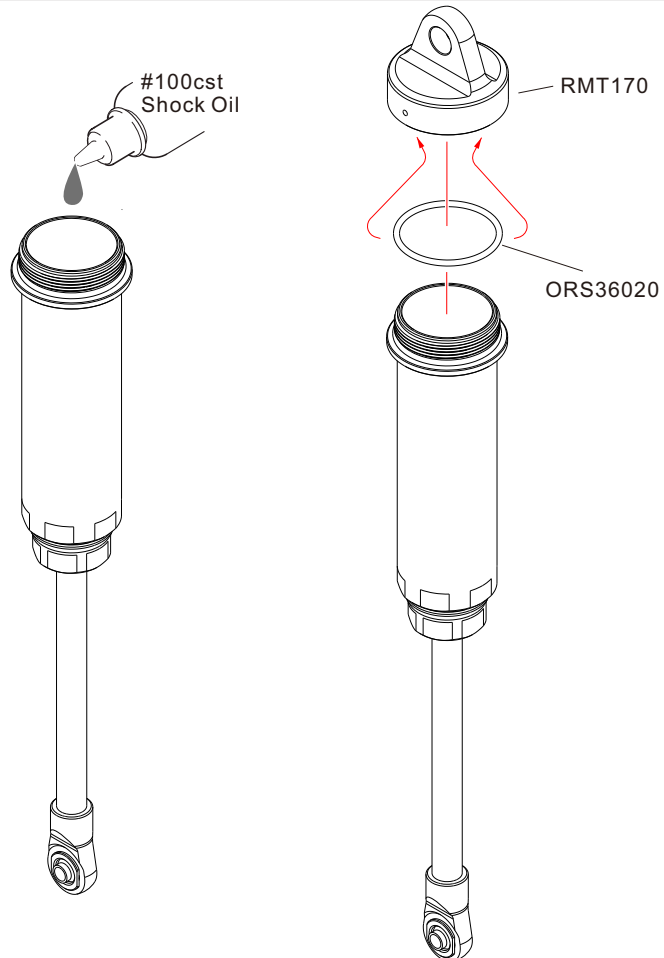

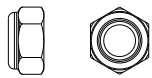

MNS50
M5 Nylon Lock Nut **x8**

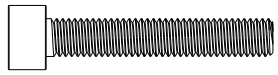

MCS5030
M5x30mm **x8**

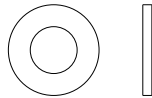

MWS061212
Washer 6x12x1.2mm **x8**



MNS60
M6 Nylon Lock Nut **x8**

65

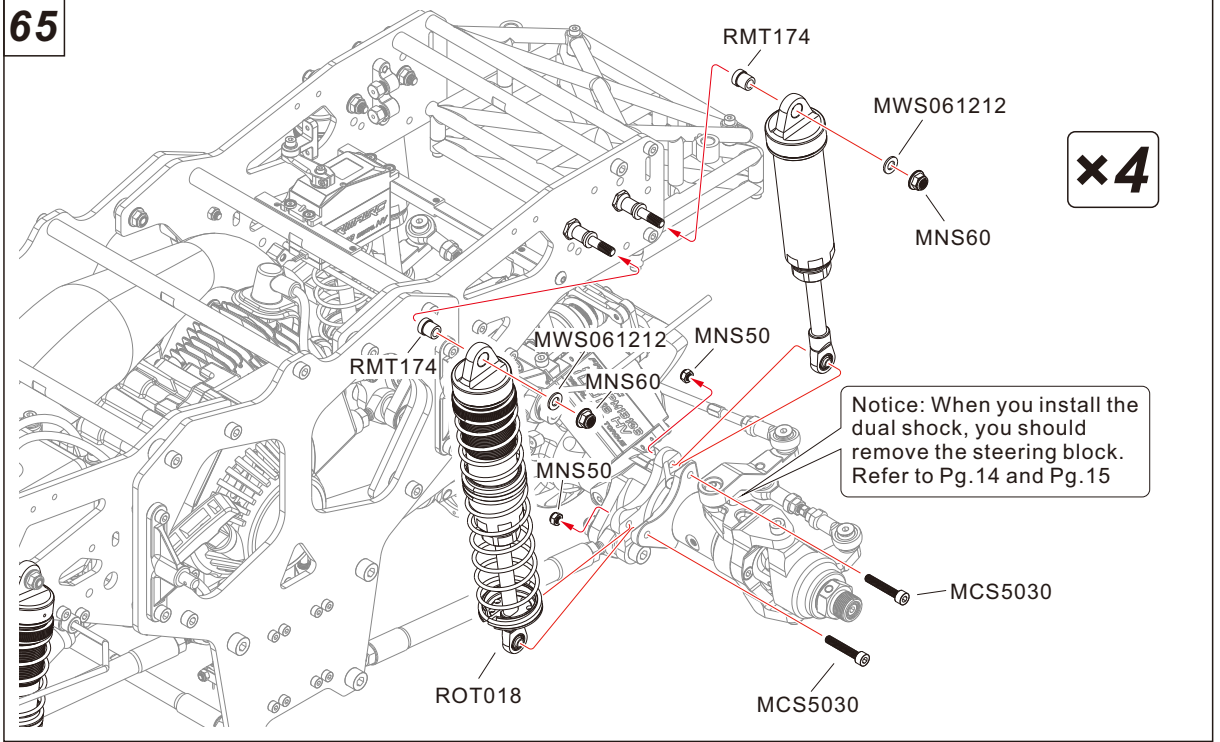

MSS3003
M3x3mm **x2**



MSS3008
M3x8mm **x2**

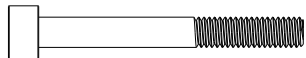

MCS4035
M4x35mm **x2**



MSS5005
M5x5mm **x4**

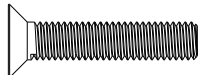

MFS5025
M5x25mm **x4**

66 Sway Bar Assembly

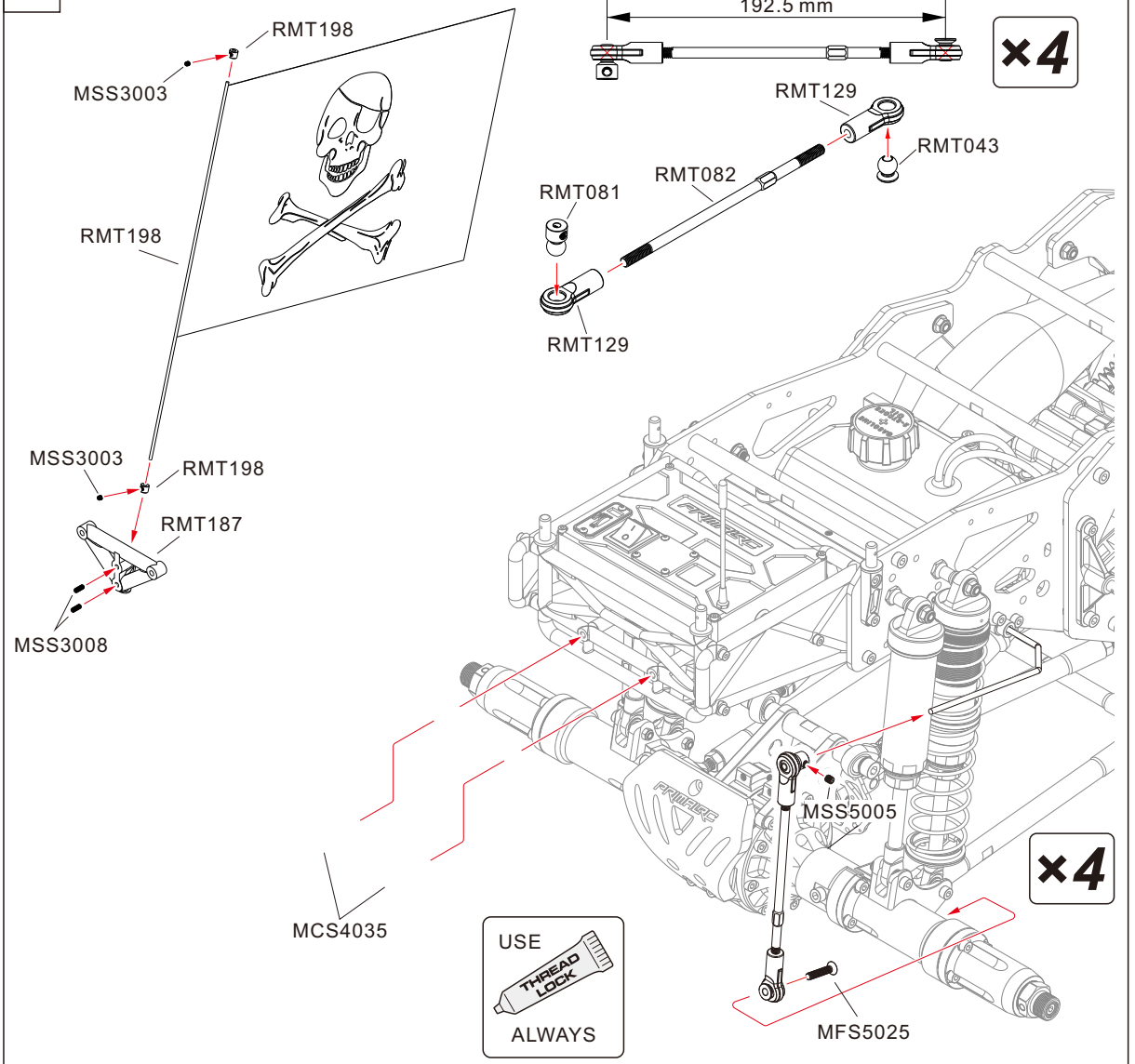

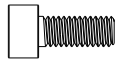

MCS4010
M4x10mm

×1

67

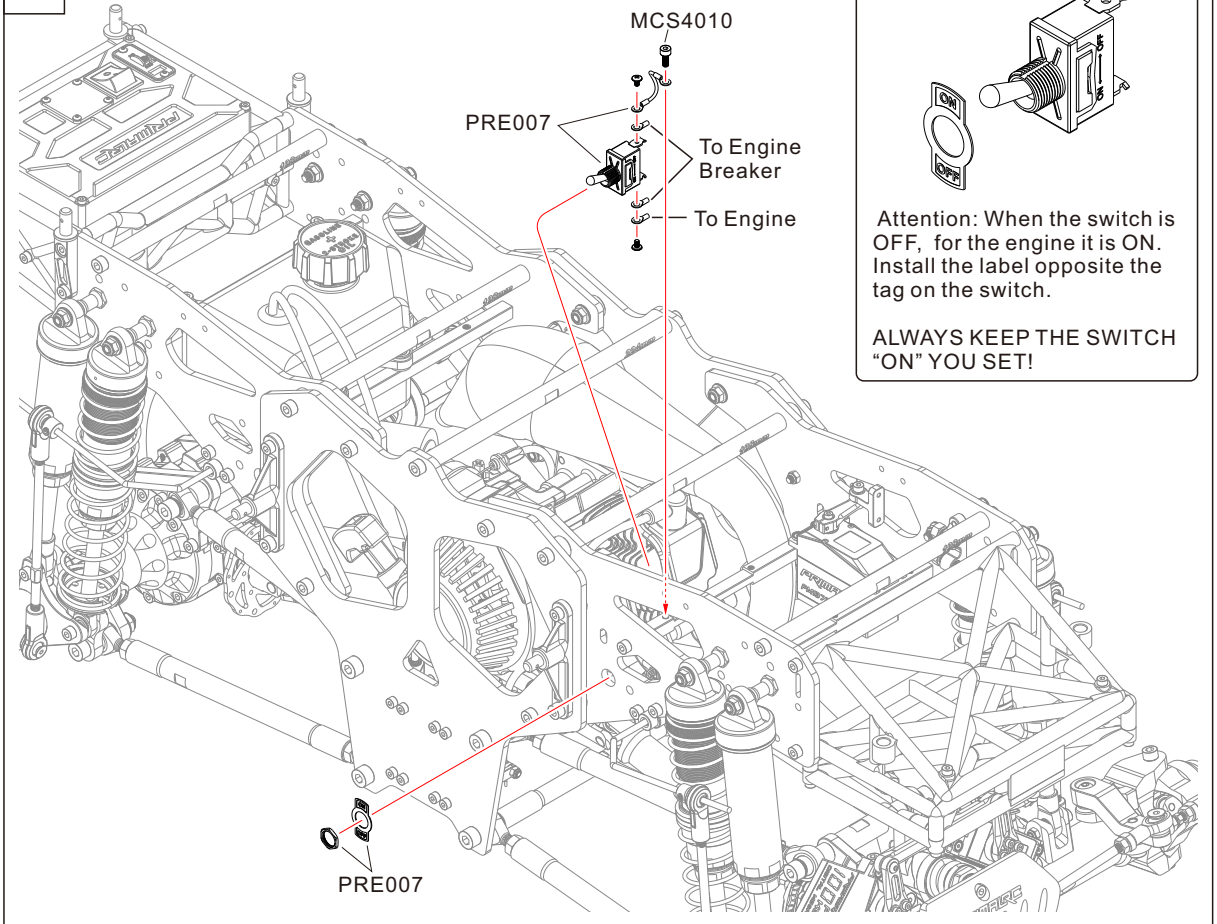

MSS4004
M4x4mm

×2

68

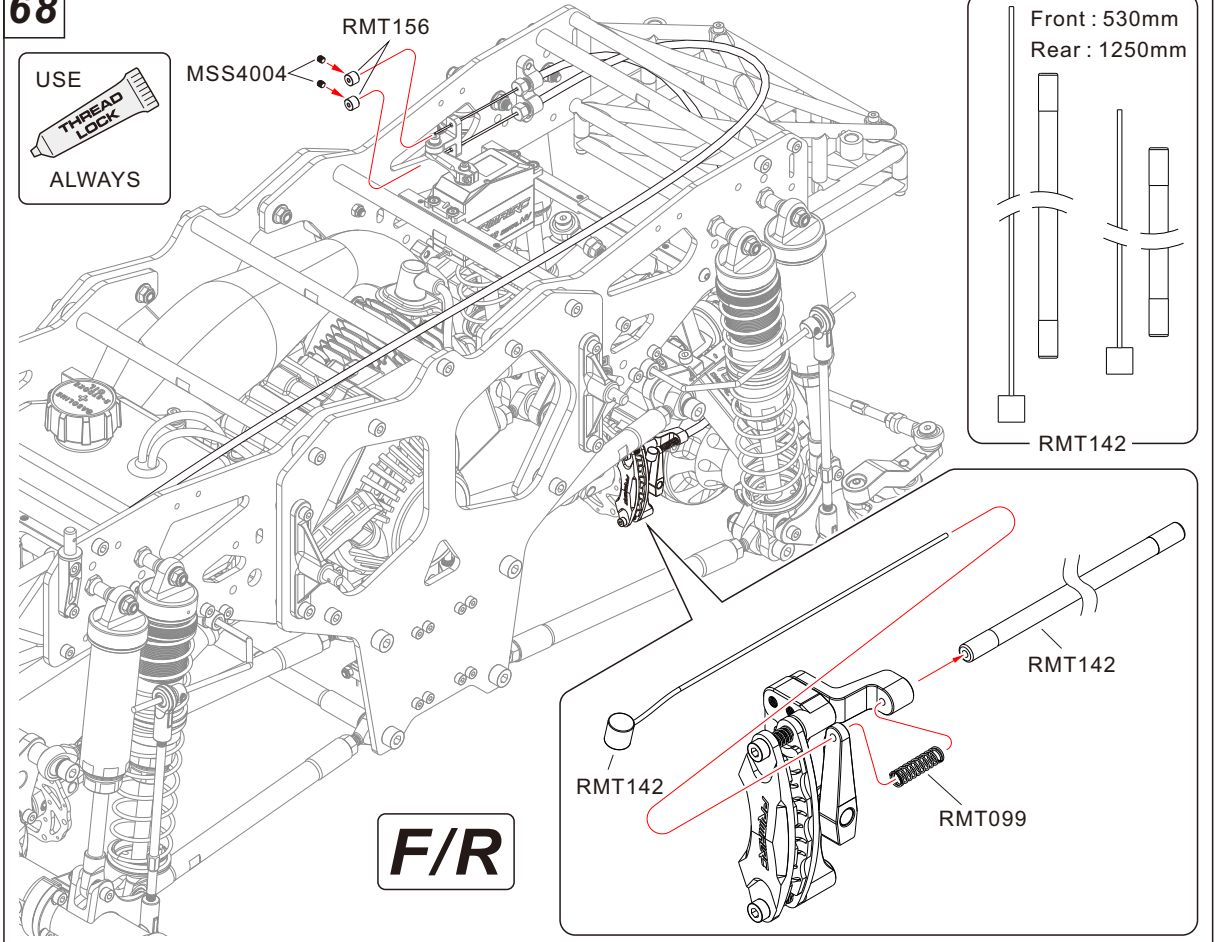



MSS4004
M4x4mm ×2

69

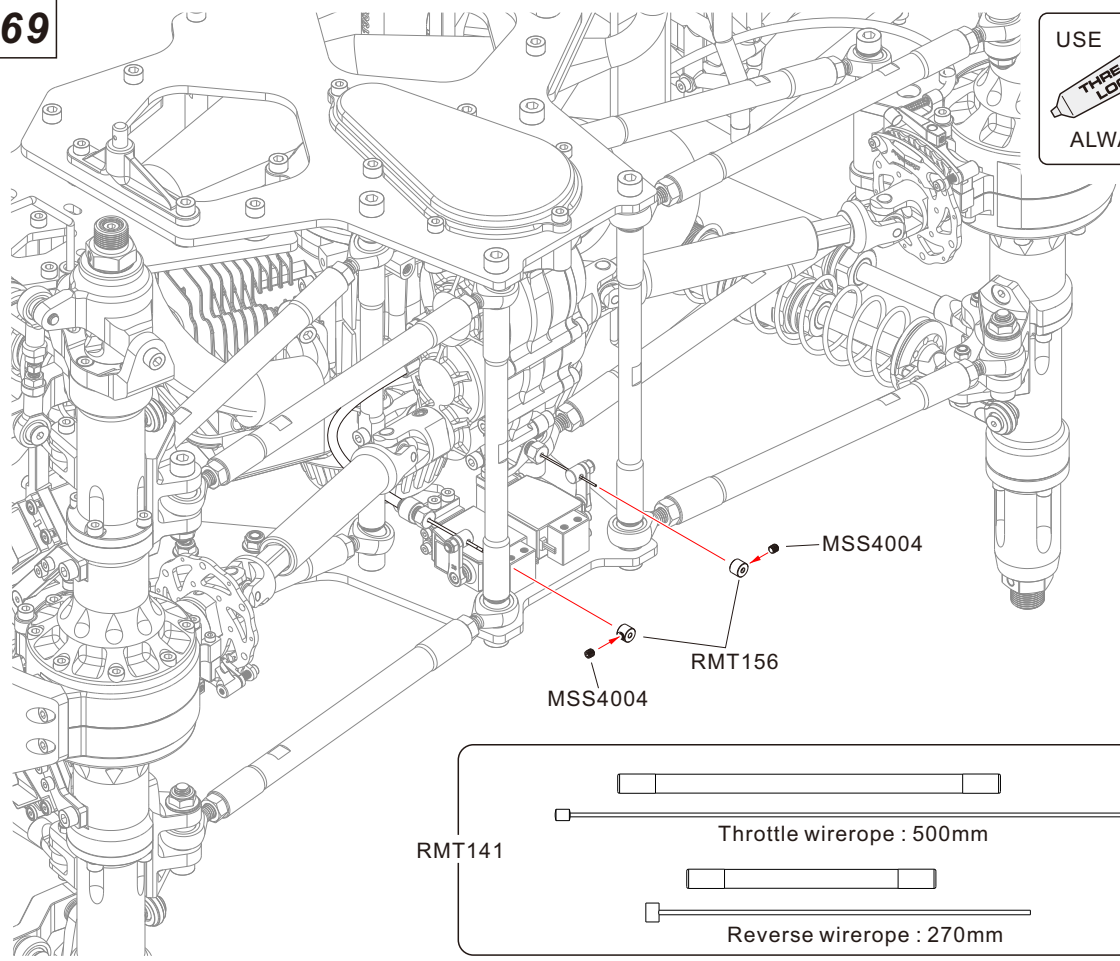

USE
THREAD
LOCK
ALWAYS

MSS4004
RMT156
MSS4004

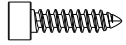
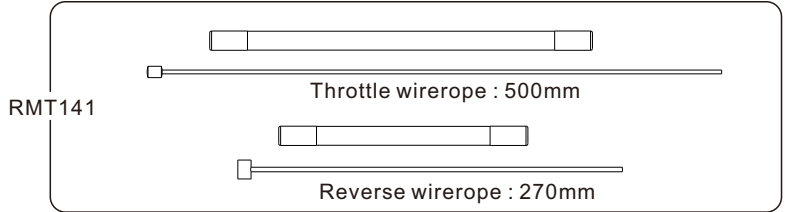

TCS3012
ST3x12mm ×2

70 Tire Assembly

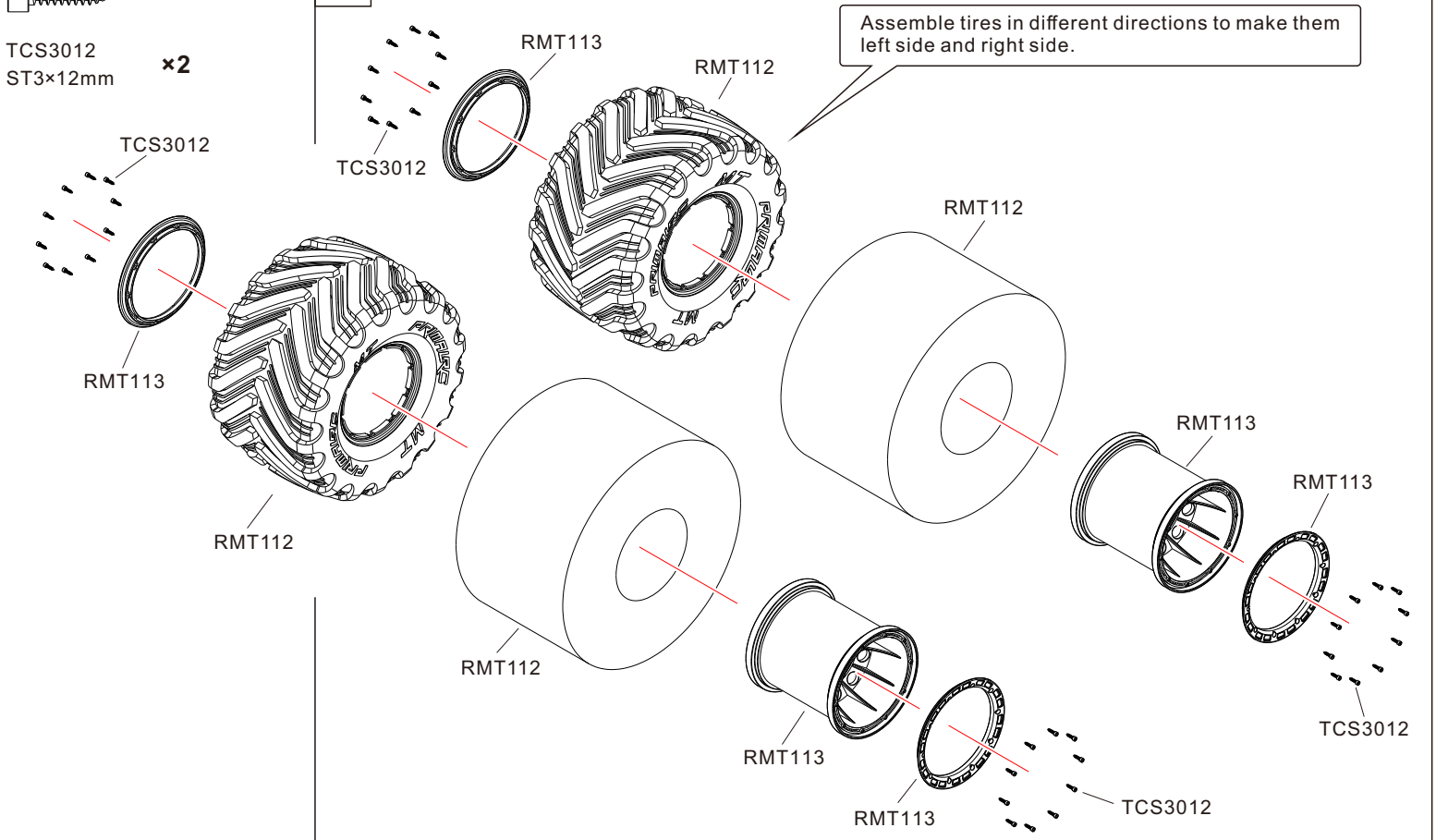

Assemble tires in different directions to make them left side and right side.

71

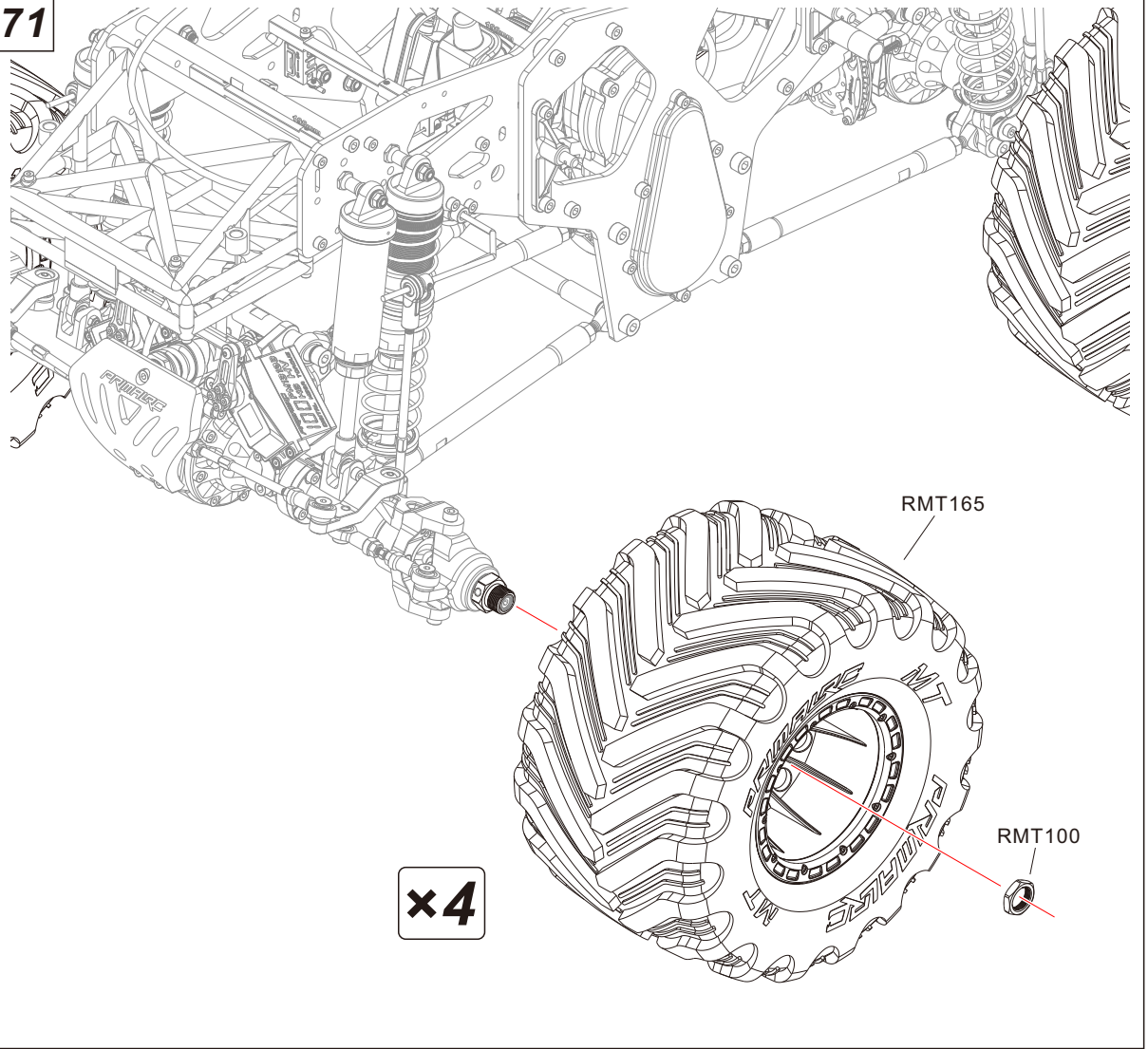

MBS4016
M4x16mm **x4**



MBS4020
M4x20mm **x2**

72 Roll Cage Assembly

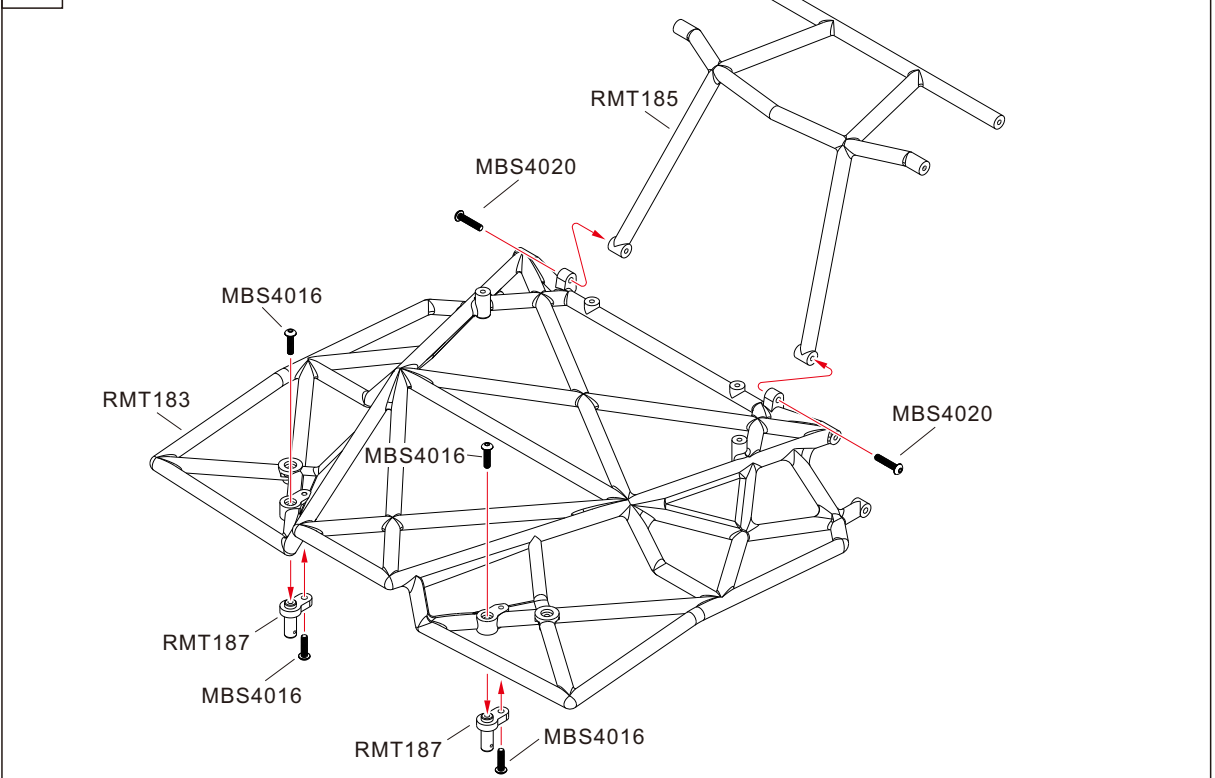

73



MBS4020
M4x20mm x1

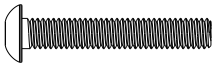

MBS4025
M4x25mm x3



MBS5014
M5x14mm x4

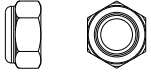

MNS50
M5 Nylon Lock Nut x4

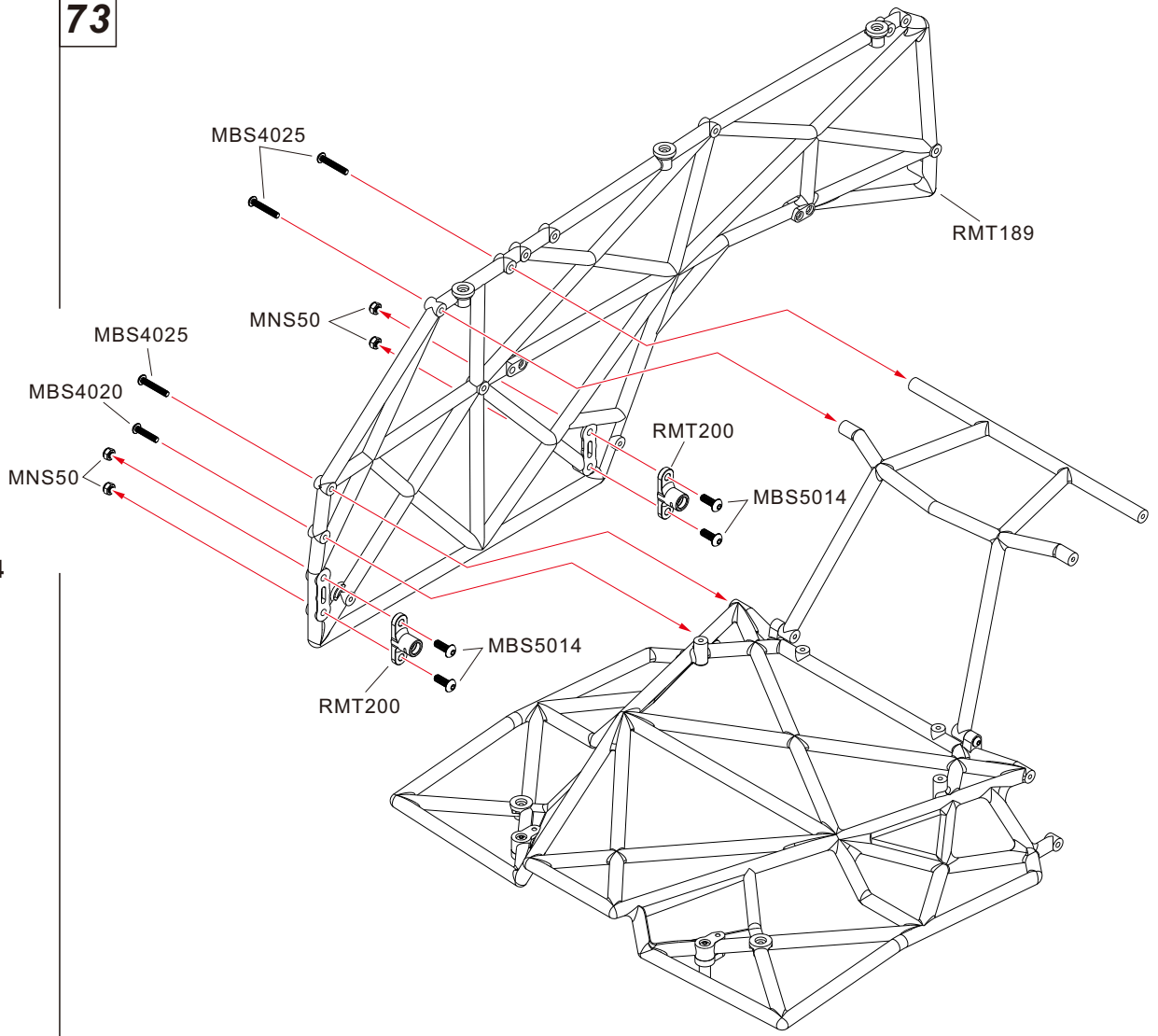

74



MBS4025
M4x25mm x4

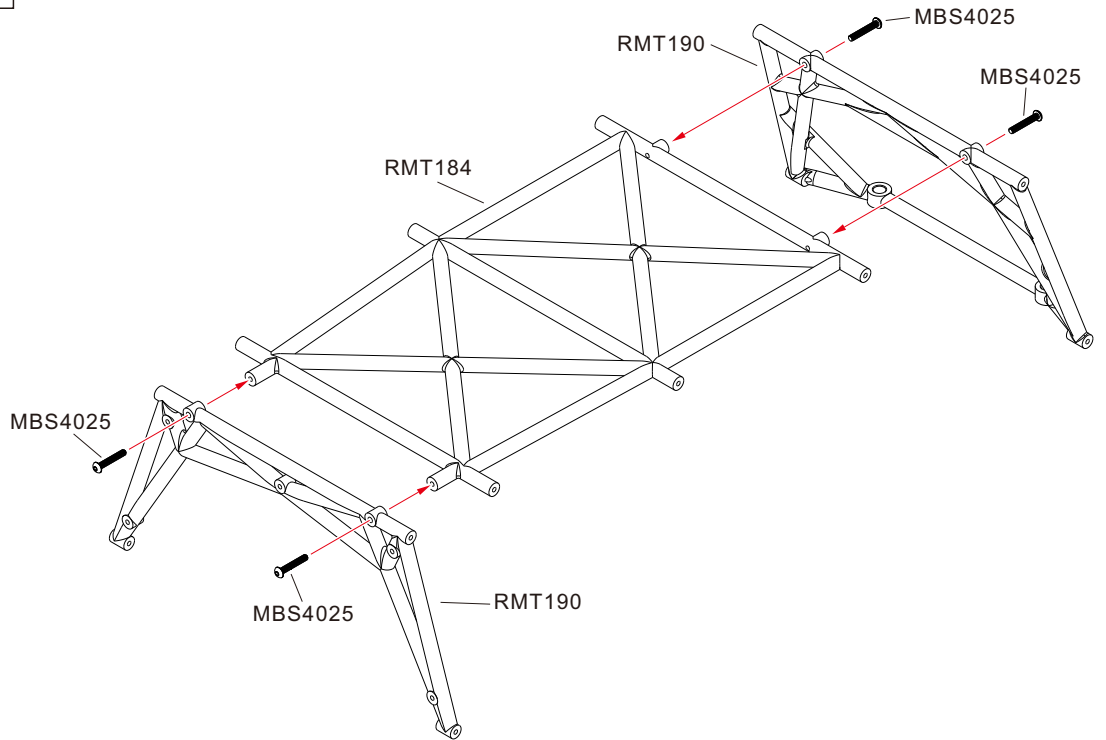



MBS4025
M4x25mm ×9

75

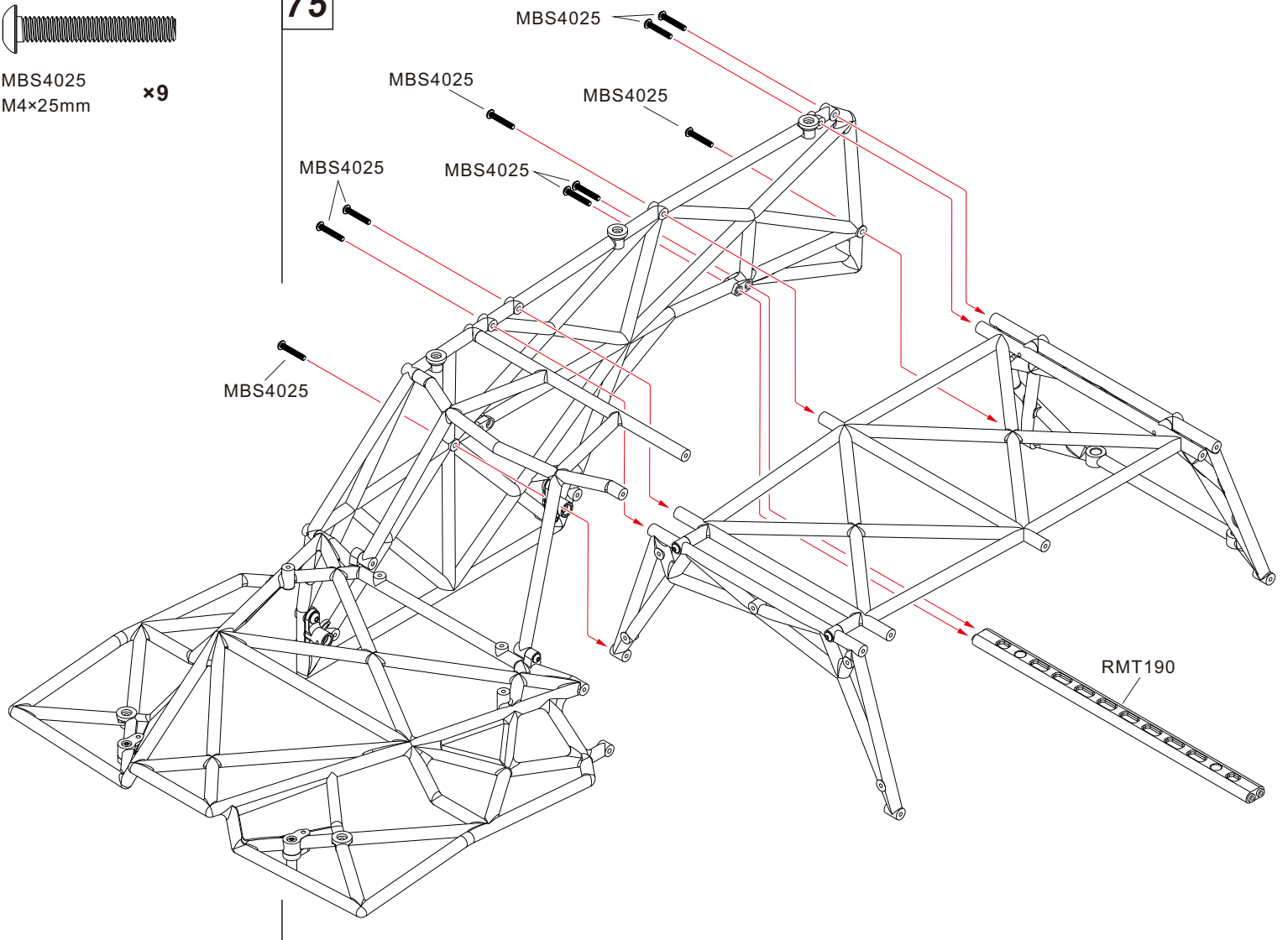

76

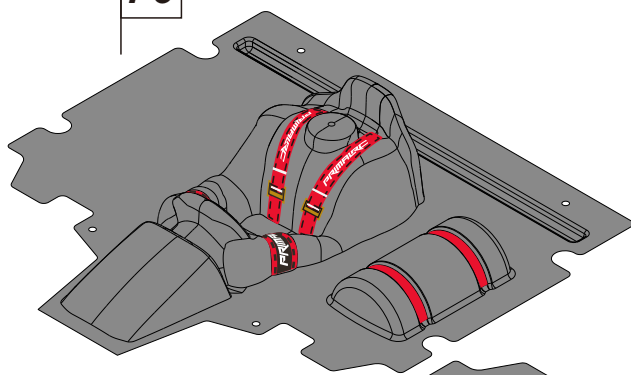

RMT197

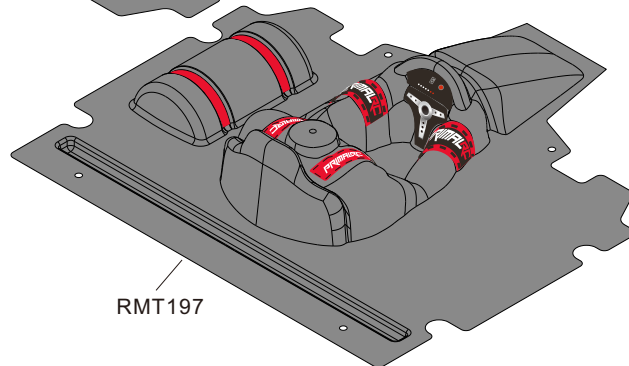

RMT197

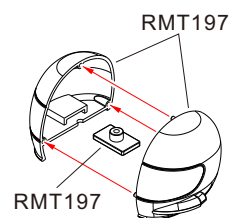

RMT197

77

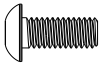

MBS4010
M4x10mm

x3



MWS040805
Washer 4x8x0.5mm

x1

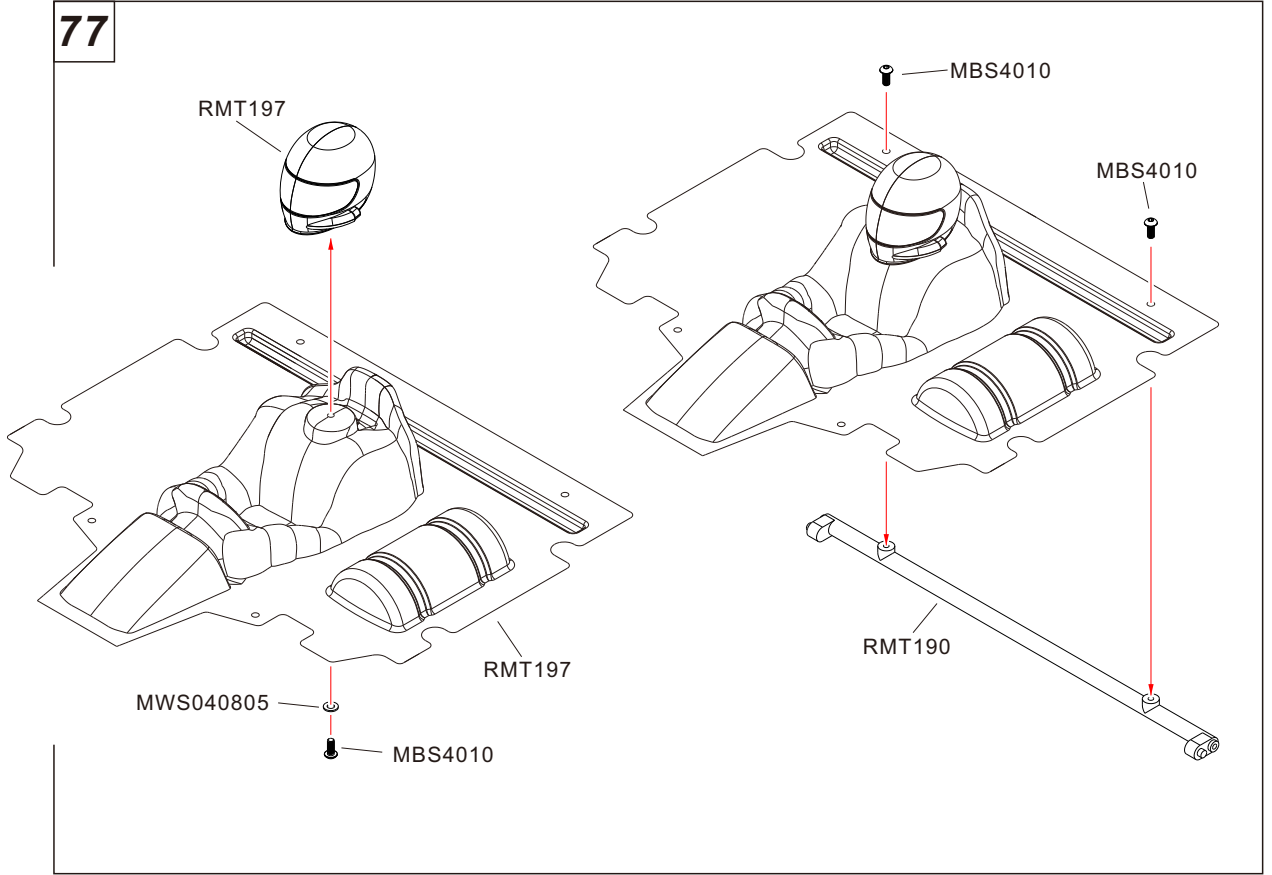

78

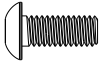

MBS4010
M4x10mm

x2



MBS4025
M4x25mm

x1

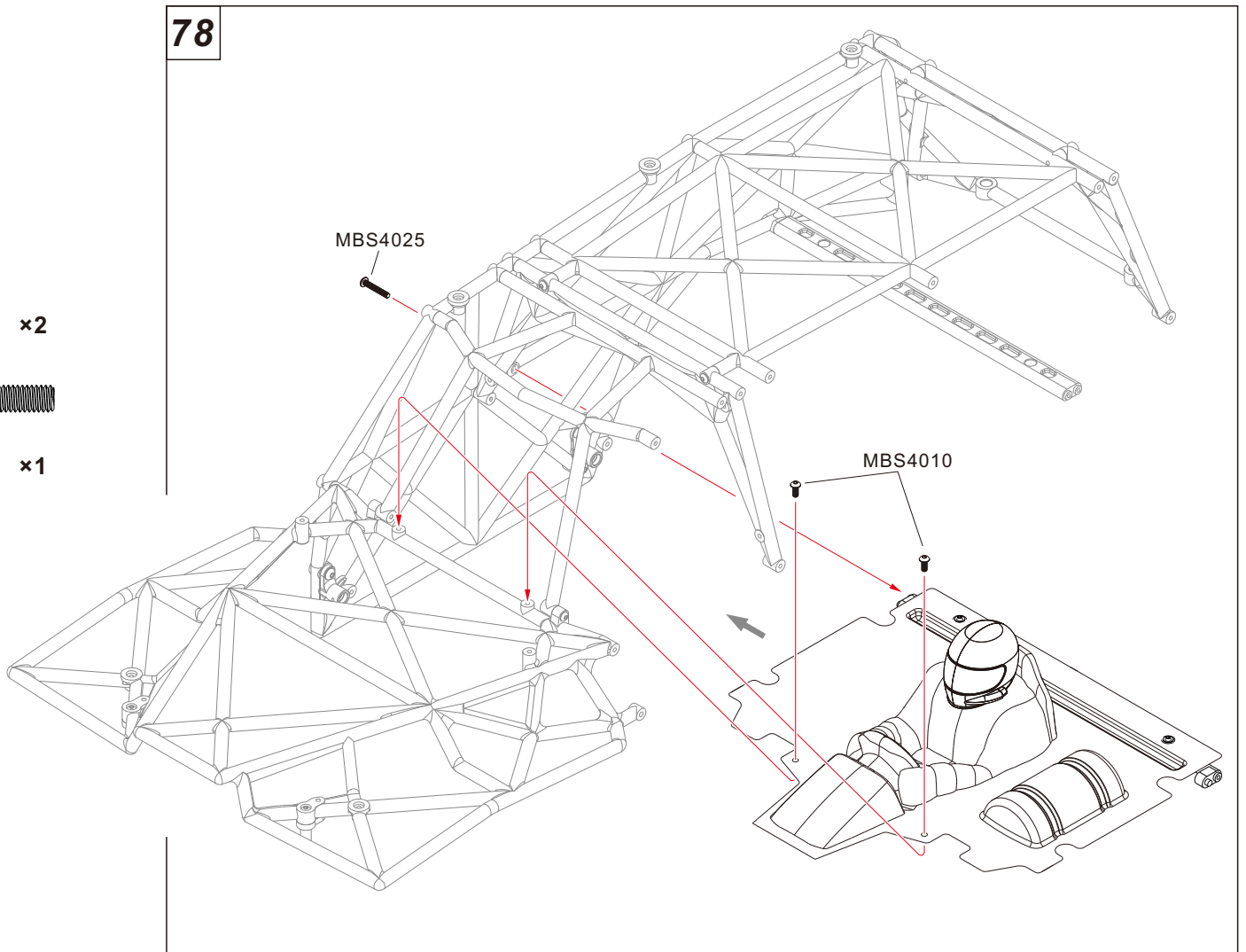

79



MBS4025
M4x25mm ×14

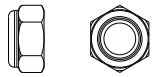

MNS50
M5 Nylon Lock Nut ×4

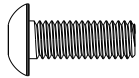

MBS5014
M5x14mm ×4

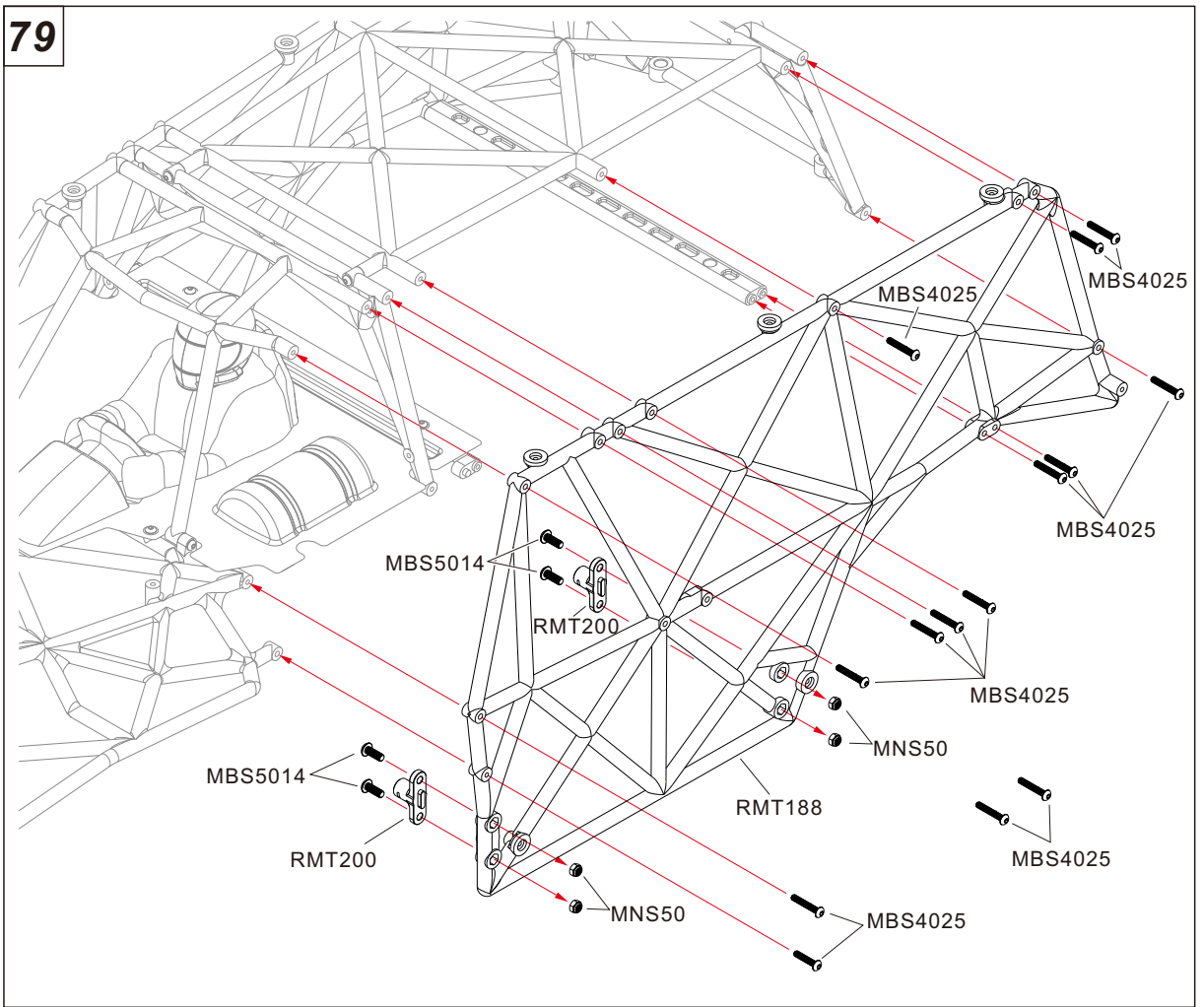

80



MCS2006
M2xmm ×2



MCS2508
M2.5x8mm ×8

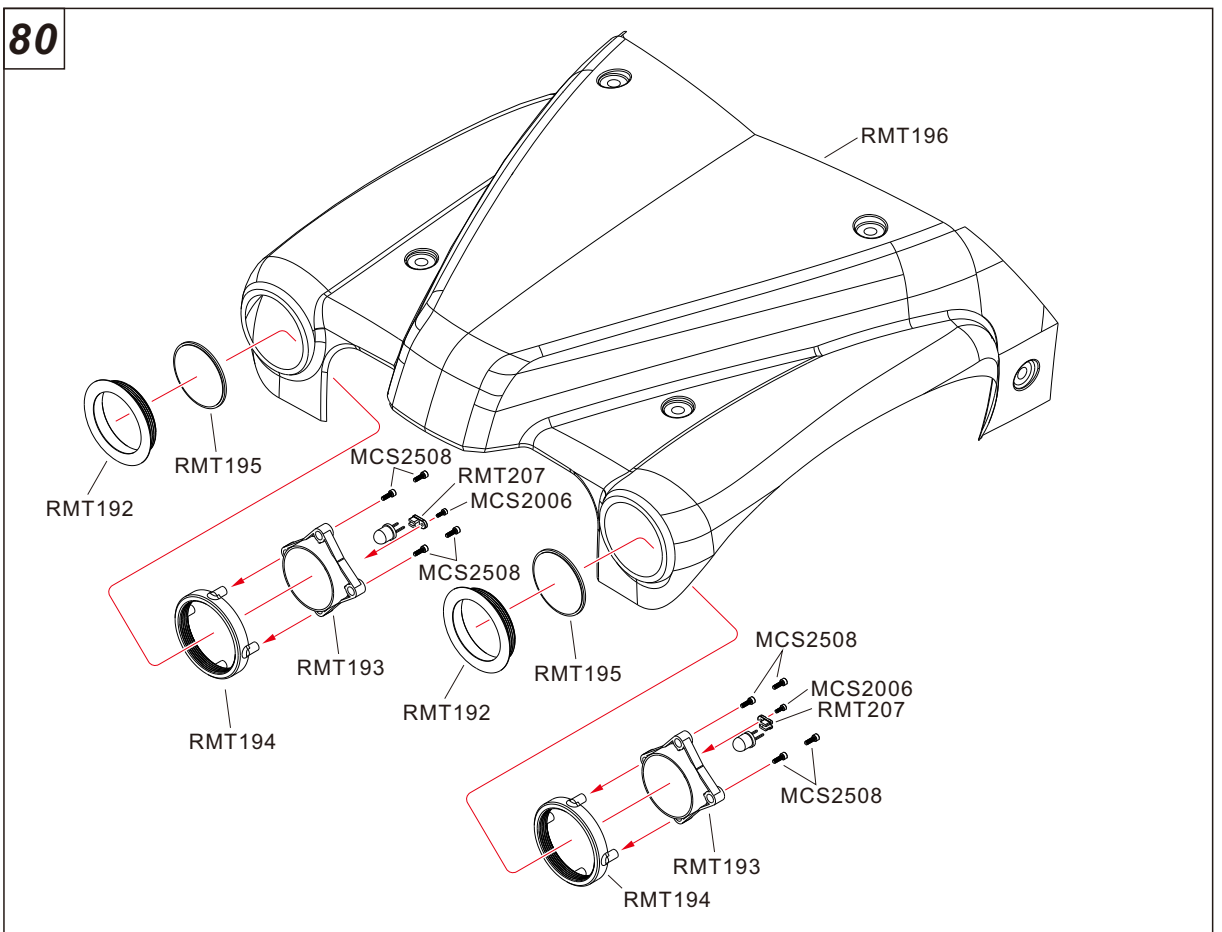



MFS4016
M4x16mm **x16**

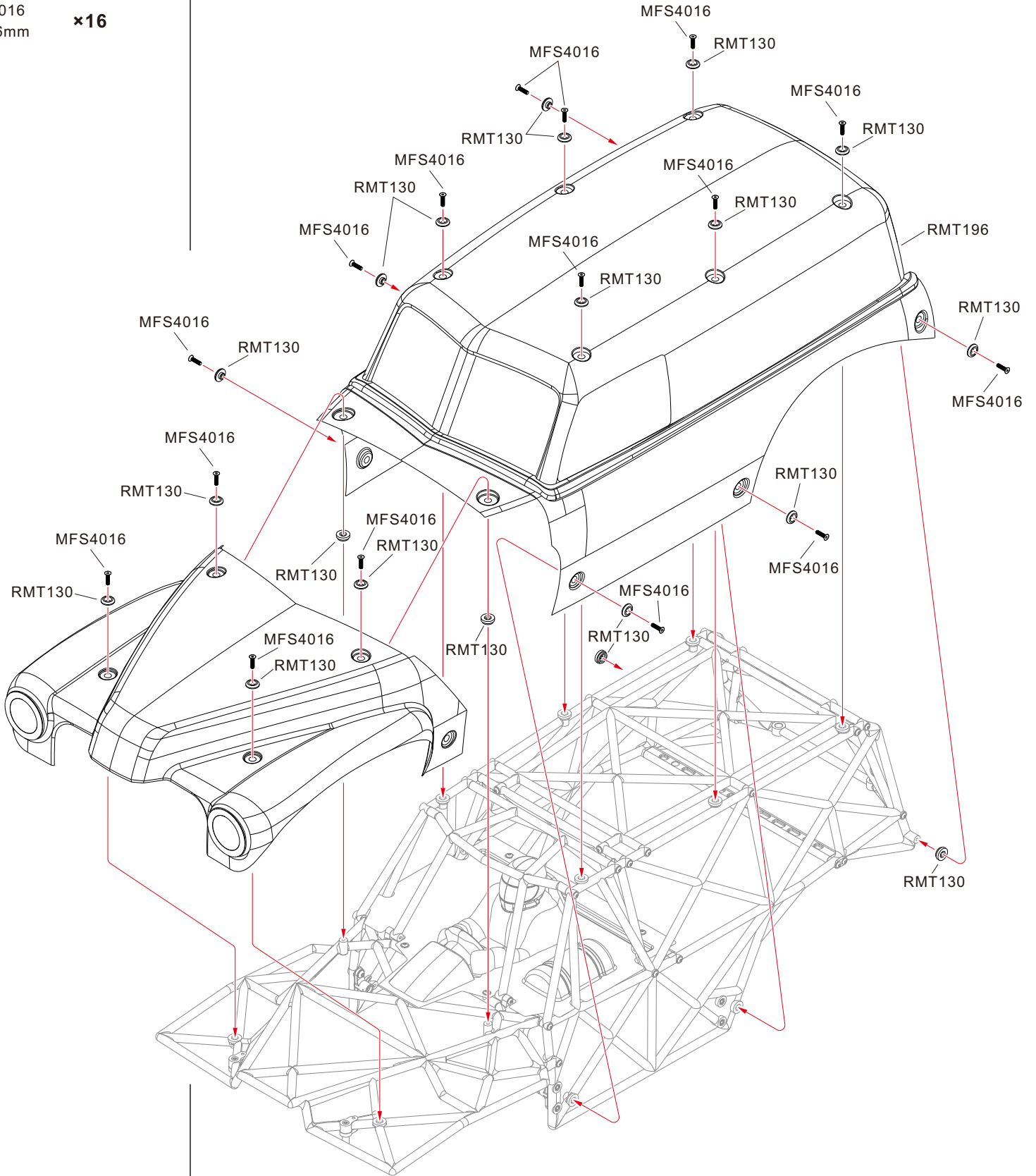

82

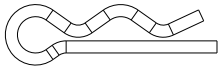

RMT150
Body Clip 8mm ×10

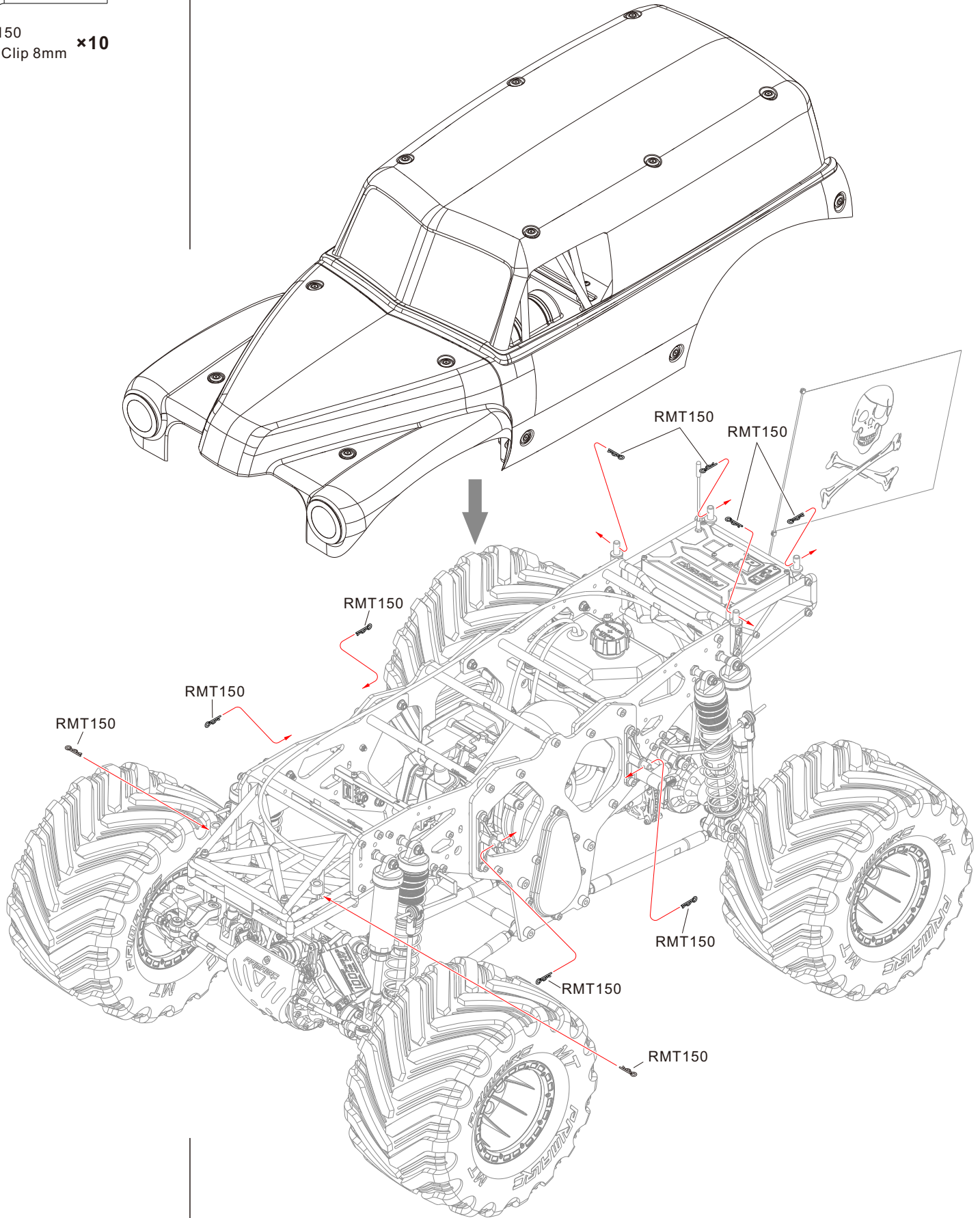

Parts list

Part No.	Description	Part No.	Description	Part No.	Description
RMT001	Differential case(1pc)	RMT106	Differential shaft(2pcs)	BBS203207	Bearing 20×32×7(4pcs)
RMT002	Solid axle set(1pc)	RMT107	Differential gear set(2pcs)	FBS152807	Flanged bearing 15×28×7(4pcs)
RMT003	Front hub carrier(2pcs)	RMT108	Inner diff Washer set(2pcs)	FBS203207	Flanged bearing 20×32×7(4pcs)
RMT004	Steering block(1pc)	RMT109	Differential completed set(1pc)	PINS5024	Pin 5×24mm (4pcs)
RMT005	Rear hub(2pcs)	RMT110	Joint bearing M6(4pcs)	MCDS12	Shaft ring 12mm(4pcs)
RMT006	Lower link mount(1pc)	RMT111	Reverse joint bearing M6(4pcs)	TCS3012	M3×12 Tp. Cap head screw(20pcs)
RMT007	Front link mount(1pc)	RMT112	MT tire with inner foam(2pcs)	MBS2506	M2.5×6 Button head screw(10pcs)
RMT008	Rear link mount(2pcs)	RMT113	MT wheel hub(2pcs)	MBS3006	M3×6 Button head screw(10pcs)
RMT009	Steering crank set(1pc)	RMT114	MT wheel completed set(2pcs)	MBS4010	M4×10 Button head screw(10pcs)
RMT010	Chain box(1pc)	RMT115	Tank set(1pcs)	MBS4012	M4×12 Button head screw(10pcs)
RMT011	Gear box(1pc)	RMT116	Rubber bushing(4pcs)	MBS4016	M4×16 Button head screw(10pcs)
RMT012	Gear box cover set(1pc)	RMT121	Left/Right auxiliary roll cage(1pc)	MBS4020	M4×20 Button head screw(10pcs)
RMT013	Shift fork(1pc)	RMT127	Rear bumper(1pc)	MBS4025	M4×25 Button head screw(10pcs)
RMT014	Engine mount(1pc)	RMT128	Rear bumper strengthen(1pc)	MBS5014	M5×14 Button head screw(10pcs)
RMT015	Steering servo mount(1pc)	RMT129	Ball end 11mm(8pcs)	MBS6020	M6×20 Button head screw(10pcs)
RMT016	Steering post mount(1pc)	RMT130	Body pad set(22pcs)	MBS6040	M6×40 Button head screw(10pcs)
RMT017	Steering link(1pc)	RMT138	Servo safe spring(1pc)	MCS2006	M2×6 Cap head screw(10pcs)
RMT018	Servo arm set(2pcs)	RMT139	Reverse return spring(2pcs)	MCS2508	M2.5×8 Cap head screw(10pcs)
RMT019	Steering link mount(1pc)	RMT141	Servo wire rope set(2pcs)	MCS3008	M3×8 Cap head screw(10pcs)
RMT020	Left main frame(1pc)	RMT142	Brake wire rope set(1pc)	MCS3012	M3×12 Cap head screw(10pcs)
RMT021	Right main frame(1pc)	RMT143	Battery strap 20×200mm(2pcs)	MCS3014	M3×14 Cap head screw(10pcs)
RMT023	Frame mount set(2pcs)	RMT144	Nylon braided tube(600mm)(1pc)	MCS3020	M3×20 Cap head screw(10pcs)
RMT024	Tank mount(2pcs)	RMT145	Differential Pad(2pcs)	MCS3028	M3×28 Cap head screw(10pcs)
RMT025	Brake servo mount(2pcs)	RMT146	Engine 49CC(1pc)	MCS4010	M4×10 Cap head screw(10pcs)
RMT028	Brake wire rope seat(1pc)	RMT147	Air filter set(1pc)	MCS4012	M4×12 Cap head screw(10pcs)
RMT029	Throttle wire rope seat(2pcs)	RMT148	Exhaust pipe set(1pc)	MCS4016	M4×16 Cap head screw(10pcs)
RMT030	Servo arm 22mm(25T)(2pcs)	RMT149	Exhaust gasket(4pcs)	MCS4020	M4×20 Cap head screw(10pcs)
RMT031	Servo arm 28mm(15T)(1pc)	RMT150	Body clip 8mm(10pcs)	MCS4025	M4×25 Cap head screw(10pcs)
RMT032	Throttle servo mount(2pcs)	RMT156	Stop collar(M4)(4pcs)	MCS4030	M4×30 Cap head screw(10pcs)
RMT033	Brake wire rope mount(1pc)	RMT157	Diff output shaft new(2pcs)	MCS4035	M4×35 Cap head screw(10pcs)
RMT034	Brake disk pad mount(2pcs)	RMT158	Gear synchronizer(1pc)	MCS5010	M5×10 Cap head screw(10pcs)
RMT035	Differential housing(1pc)	RMT159	Synchronizer shaft(1pc)	MCS5012	M5×12 Cap head screw(10pcs)
RMT036	Brake disk(2pcs)	RMT168	10mm Shock shaft(2pcs)	MCS5014	M5×14 Cap head screw(10pcs)
RMT037	Sway bar mount(4pcs)	RMT169	10mm Shock absorber(2pcs)	MCS5016	M5×16 Cap head screw(10pcs)
RMT038	Bumper(1pc)	RMT170	10mm Shock cap(2pcs)	MCS5020	M5×20 Cap head screw(10pcs)
RMT039	Servo saver set(1pc)	RMT171	10mm Shock spring mount(2pcs)	MCS5025	M5×25 Cap head screw(10pcs)
RMT041	Steering post(1pc)	RMT172	10mm Shock piston(2pcs)	MCS5030	M5×30 Cap head screw(10pcs)
RMT042	Spacer 16mm(1pc)	RMT173	10mm Shock ballend(2pcs)	MCS5035	M5×35 Cap head screw(10pcs)
RMT043	11mm Ball(4pcs)	RMT174	10mm Shock top mount(2pcs)	MCS5040	M5×40 Cap head screw(10pcs)
RMT044	King pin bushing(4pcs)	RMT175	Shock spring D42.5×110mm(2pc)	MCS6010	M6×10 Cap head screw(10pcs)
RMT045	Upper link mount(2pcs)	RMT176	Shock spring D42.5×140mm(2pcs)	MCS6016	M6×16 Cap head screw(10pcs)
RMT046	24mm Wheel hex hub(2pcs)	RMT177	10mm shock seal set(1pc)	MCS6020	M6×20 Cap head screw(10pcs)
RMT047	Upper link 180mm(2pcs)	RMT179	Frame for Grave Digger(2pcs)	MCS6025	M6×25 Cap head screw(10pcs)
RMT048	Lower link 200mm(2pcs)	RMT180	Damping cylinder(1pc)	MCS6030	M6×30 Cap head screw(10pcs)
RMT049	6×45mm Turnbuckle(2pcs)	RMT181	Damping cylinder shaft(2pcs)	MCS6035	M6×35 Cap head screw(10pcs)
RMT050	6×125mm Turnbuckle(2pcs)	RMT182	Sway bar set(2pcs)	MCS6065	M6×65 Cap head screw(10pcs)
RMT052	Universal drive shaft set(2pcs)	RMT183	Grave Digger front roll-cage(1pc)	MCS8040	M8×40 Cap head screw(10pcs)
RMT053	Straight axle shaft(2pcs)	RMT184	Grave Digger top roll-cage(1pc)	MCS8045	M8×45 Cap head screw(10pcs)
RMT054	Drive shaft(1pc)	RMT185	Grave Digger front pipe frame(1pc)	MCS8050	M8×50 Cap head screw(10pcs)
RMT055	Shaft screw(4pcs)	RMT186	Grave Digger rear pipe frame(1pc)	MFS3005	M3×5 Flat head screw(10pcs)
RMT056	Sprocket shaft(1pc)	RMT187	Flag mount(2pcs)	MFS3010	M3×10 Flat head screw(10pcs)
RMT057	Clutch bell 58mm(1pc)	RMT188	Grave Digger left roll-cage(1pc)	MFS3014	M3×14 Flat head screw(10pcs)
RMT058	Link 198mm(2pcs)	RMT189	Grave Digger right roll-cage(1pc)	MFS3016	M3×16 Flat head screw(10pcs)
RMT059	Link 224mm(1pc)	RMT190	Grave Digger roll-cage mount(1pc)	MFS4010	M4×10 Flat head screw(10pcs)
RMT060	Link 190mm(2pcs)	RMT191	Grave Digger front bumper(1pc)	MFS4012	M4×12 Flat head screw(10pcs)
RMT061	Link 170mm(2pcs)	RMT192	Grave Digger head light ring(2pcs)	MFS4016	M4×16 Flat head screw(10pcs)
RMT062	Operate screw(2pcs)	RMT193	Grave Digger head light house(2pcs)	MFS5016	M5×16 Flat head screw(10pcs)
RMT063	Gear Hex mount(1pc)	RMT194	Grave Digger head light mount(2pcs)	MFS5025	M5×25 Flat head screw(10pcs)
RMT066	Rear output shaft(1pc)	RMT195	Grave Digger head light lens(2pcs)	MFS6016	M6×16 Flat head screw(10pcs)
RMT067	Front output shaft(1pc)	RMT196	Grave Digger painted body(1pc)	MFS6020	M6×20 Flat head screw(10pcs)
RMT068	Wire rope mount(1pc)	RMT197	Grave Digger cockpit(1pc)	MFS6025	M6×25 Flat head screw(10pcs)
RMT069	Shift fork shaft(2pcs)	RMT198	Skull flag(1pc)	MES40	E-clip 4mm(10pcs)
RMT070	Spacer M8×2.5mm(8pcs)	RMT199	Clamp for spark plug cover(1pc)	MES70	E-clip 7mm(10pcs)
RMT071	Spacer M8×12.5mm(8pcs)	RMT200	Aluminum body mounts(1pc)	MNS40	M4 Nylon nut(10pcs)
RMT080	Spacer M6(6pcs)	RMT205	Grave Digger standard stickers(1pc)	MNS50	M5 Nylon nut(10pcs)
RMT081	11mm Ball(4pcs)	RMT207	LED mount(10pc)	MNNS60	M6 Nut(10pcs)
RMT082	6×159mm Turnbuckle(2pcs)	ROT015	CNC battery box set(1pc)	MNRS60	M6 Reverse nut(10pcs)
RMT083	Sprocket 10T(1pc)	PRE001	Fail safe engine breaker(1pc)	MNFS60	M6 Flanged nylon nut(10pcs)
RMT084	Sprocket 30T(1pc)	PRE002	GT5 Transmitter with receiver(1pc)	MNFS80	M8 Flanged nylon nut(10pcs)
RMT085	Spiral bevel gear 15T(1pc)	PRE003	GT5 receiver(1pc)	MNNS80	M8 Nut(10pcs)
RMT086	Spiral bevel gear 45T(1pc)	PRE005	PM1373 Servo(73KG)(1pc)	MSS3003	M3×3 Set screw(10pcs)
RMT087	Spiral bevel gear 17T(1pc)	PRE006	SC5000mAh 7.2V Ni-MH Batt.(1pc)	MSS3008	M3×8 Set screw(10pcs)
RMT088	Spiral bevel gear 34T(2pcs)	PRE007	Engine switch(1pc)	MSS4004	M4×4 Set screw(10pcs)
RMT089	Drive gear 20T(2pcs)	PRE009	PM1623HV servo(23KG)(1pc)	MSS5005	M5×5 Set screw(10pcs)
RMT090	Drive gear 20T/30T(1pc)	PRE011	PM13103HV servo(100KG)(1pc)	MPS50	Spring washer M5(10pcs)
RMT091	Drive gear 23T/27T(1pc)	PRE013	10mm LED for Grave Digger(1pc)	MPS60	Spring washer M6(10pcs)
RMT092	Drive gear 25T(2pcs)	ORS14020	O-ring D14×2(4pcs)	MWS030810	Washer 3×8×1(10pcs)
RMT093	Chain(1pc)	ORS22025	O-ring D22×2.5(4pcs)	MWS040805	Washer 4×8×0.5(10pcs)
RMT094	Joint bearing M8(4pcs)	ORS23020	O-ring D23×2(4pcs)	MWS061212	Washer 6×12×1.2(10pcs)
RMT095	Brake disk pad(2pcs)	ORS36020	O-ring D36×2(4pcs)	MWS061612	Washer 6×16×1.2(10pcs)
RMT096	Brake arm(2pcs)	ORS38020	O-ring D38×2(4pcs)	MWS101510	Washer 10×15×1(10pcs)
RMT097	Brake shaft(2pcs)	BBS050825	Bearing 5×8×25(4pcs)	MWS202810	Washer 20×28×1(10pcs)
RMT098	Wire rope mount screw(4pcs)	BBS092006	Bearing 9×20×6(4pcs)		
RMT099	Brake spring set(2pcs)	BBS101504	Bearing 10×15×4(4pcs)		
RMT100	24mm Wheel nut(4pcs)	BBS101905	Bearing 10×19×5(4pcs)		
RMT102	Spacer M3(2pcs)	BBS102206	Bearing 10×22×6(4pcs)		
RMT103	Servo bushing(4pcs)	BBS122406	Bearing 12×24×6(4pcs)		
RMT105	Antenna pipe set(1pc)	BBS152807	Bearing 15×28×7(4pcs)		